



Sensata
Technologies



KLIXON[®]

PRECISION SWITCHES

2	Introduction to KLIXON® precision switches
5	KLIXON® AT Series – Snap Action Precision Position Switches (rated 4 amps @ 28VDC)
21	KLIXON® 10AT / 11AT / 12AT Series – Hermetic Control Switches
23	KLIXON® 10AT-MIL Series – Military Qualified Snap Action Precision Position Switches
31	KLIXON® KX Series – Precision Sine Switches (rated 10 amps @ 28VDC, 120VAC)
37	KLIXON® 4HVS Series – High Performance Hermetic Interlock Switches
39	KLIXON® ESS Series – Environmentally Sealed High Performance Position Switches
41	KLIXON® 6PS & 7PS Series – Hermetic Stainless Steel Pressure Switches
49	KLIXON® 2SE Series – Solid-State Airflow Sensors
53	MIL-SPEC Qualification List & “Closest Match” Cross Reference



INTRODUCTION TO KLIXON® PRECISION SWITCHES

- Hermetically sealed with dry nitrogen gas backfill
- Excellent shock and vibration resistance
- Switching up to 10 amps
- Optimal for low level circuits
- Temperature range between -275°F and 450°F
- Single and multiple pole designs available
- Small, axis-symmetric design for robustness and reliability
- Small and lightweight
- Various mounting configurations for custom applications
- Sealed and unsealed plunger options
- Wide range of side plate designs for narrow width applications
- Proven snap-action switching, reliable performance and long life
- MIL-S-8805 qualification option
- Approvals for various space, weapons, military and commercial aircraft OEMs

KLIXON® hermetic miniature and sub-miniature snap-action switches are ideal for extremely harsh and demanding environments as found in aircraft, military, aerospace, and aircraft engines applications. KLIXON® precision hermetic switches have been used for over 40 years in a wide range of applications, and can be found on virtually all commercial and military aircraft, as well as various space vehicles and satellites worldwide.

Sensata specializes in custom and semi-custom solutions. Over time we have built-up a design library of over 2,000 switch packages, and have an off the shelf solution to meet most standard and non-standard needs.

We offer a wide choice of precision switches ideally suited for rugged and high cost of failure applications. Sensata Technologies also manufactures a hermetically sealed snap-acting pressure switch line for applications in aerospace and electronics where high reliability and resistance to severe environments is essential.

APPLICATIONS

- Aircraft landing gear and helicopter weight-on-wheels
- Valve position indication in aircraft engines and APU's
- Aircraft environmental control systems and engine controls
- Aircraft flight control surfaces
- Stores away (munitions)
- Door stairway indication
- Brake controls
- Parachute openers
- Bomb racks and ejectors
- APUs
- Satellite panel indication and satellite arm indication
- Pilot ejection seats
- Missile launchers
- Thrust reversers
- Explosive actuators
- EVA equipment
- IUS platform
- Hydraulic / servo controls
- Engine valve indication
- Gearboxes
- Warhead safety circuits
- Weapon firing systems and trigger switches
- Rocket motor controls
- Space station

NOMENCLATURE

Precision hermetic switches are often referred to as:

- Aerospace switches
- Aircraft switches
- Hermetic switches
- Limit switches
- Military switches
- Position switches
- Miniature switches
- Sensitive switches
- Switches

TECHNICAL TERMS

Electrical Life

The minimum number of cycles allowable for a switch under a specified combination of electrical load, actuation and environmental criteria. Usually specified for the maximum current and temperature rating of the switch.

Mechanical Life

The minimum number of cycles allowable for a switch with no electrical load, and a specified combination of actuation and environmental criteria.

Contact Erosion

A general loss of material from one or both surfaces of a pair of mating contacts. This is as a result of switching electrical loads.

Pole

The number of completely separate circuits contained in a switch. A single pole switch can control only one circuit at a time. A double pole switch can control two independent circuits at the same time.

Throw

The number of circuits that each individual pole of a switch can control. The number of throws is completely independent of the number of poles.

Contact Resistance

The resistance offered to flow of current during its passage between electrical contacts. For practical reasons, lead and terminal resistance may be included in the actual measurement, as well as the contact resistance proper.

Termination Leads or Connectors

Sensata uses 20 gauge wire per MIL-W-22759 as shown below. Alternative gauges, MIL specs and color coding schemes are available upon request. Sensata will also provide switches with connectors to meet customer application needs.

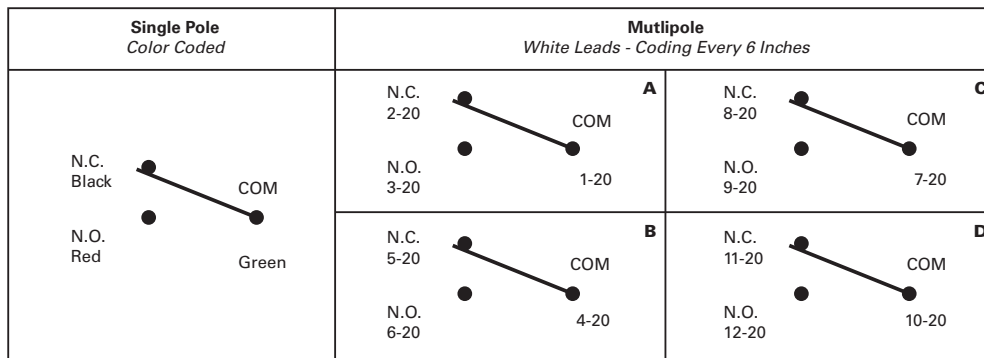

Terminal Identification
 Red = Normally Open
 Green = Common
 Black = Normally Closed

Wire Leads
 AWG 20 MIL-W-22759/9

NOTE:
 Diagrams show circuits when actuator is in free position.

Dielectric Withstanding Voltage *

The maximum voltage that a switch can withstand between specified points without leakage current exceeding a specified value.

Insulation Resistance *

The resistance offered by the insulating members of a component part to a direct voltage tending to produce a leakage current through or on the surface of these members. Insulation resistance should not be considered the equivalent of dielectric withstanding voltage.

** Insulation resistance measurements should not be considered to be equivalent to dielectric withstand voltage tests. A clear, dry insulation may have a high insulation resistance and yet possess a mechanical fault that would cause failure in the dielectric withstand voltage test. Conversely, a dirty, deteriorated insulation with a low insulation resistance might not break down under a high potential of a DWV test.*

Loads

Three types of loads associated with electrical switches are: resistive, inductive and lamp. Of concern when discussing loads are their effect on the switch contacts.

Resistive

Purely resistive loads are the easiest to switch. Contact life is maximized when switching purely resistive loads because contact erosion is minimized.

Inductive

Inductive loads result in the most contact erosion. This is due to the tendency of the current to continue travelling across the contact while opening, causing arcing.

Lamp

In-rush current is the condition that result in the lamp load rating. The resistance rating of a lamp is normally specified when the lamp is hot. However, when the lamp is cold the resistance is low. This in-rush current can be 10 times the normal current, resulting in welding of the contacts.

Low Level Circuit

Low level circuits are classified in MIL-8805 as those with resistive loads less than 10mA at 30mV. The use of gold plated contacts and the hermetic enclosure of the switch contacts afford an ideal environment for switching low level loads.

Pretravel

The distance the button moves from the free position to the actuation point.

Free Position

The position of the button when there is no external force other than gravity applied to it.

Actuation Point

The position of the button at which the movable contact snaps from the normally closed contact position to the normally open contact position.

Release Position

The position of the button at which the movable contact snaps from the normally open contact position to the normally closed contact position.

Maximum Overtravel Position

The position of the button when the positive overtravel stop is reached. Further overtravel would damage the switch.

Actuation Force

The force which must be applied to the button to cause the movable contact to snap from the normally closed contact position to the normally open contact position.

Release Force

The level to which the force on the button must be reduced to allow the contacts to snap from the normally open position to the normally closed contact position.

Overtravel

The distance that the button can travel beyond the actuation point.

Movement Differential

The distance the button moves from the actuation point to the release point.

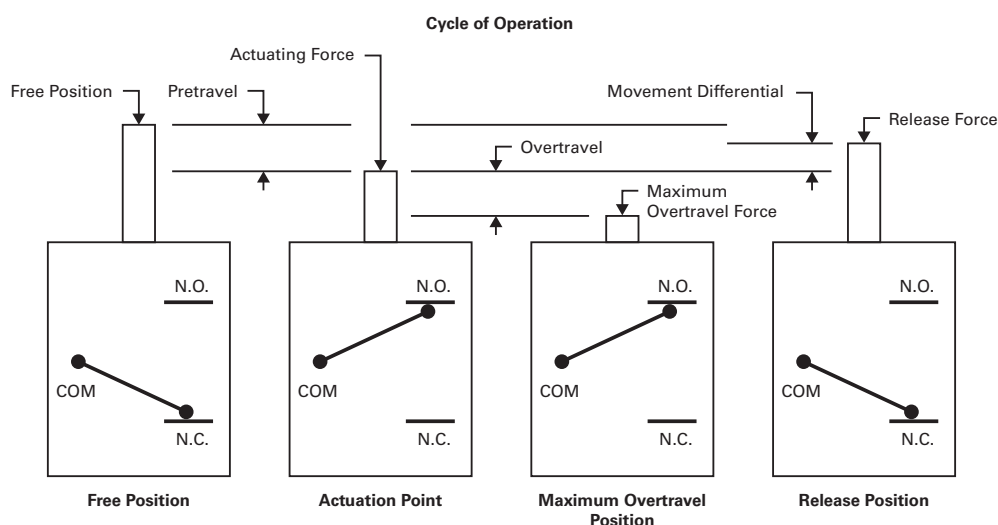
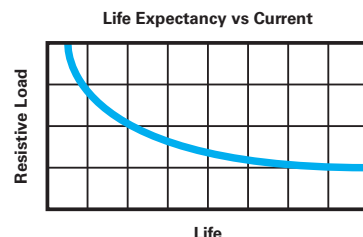

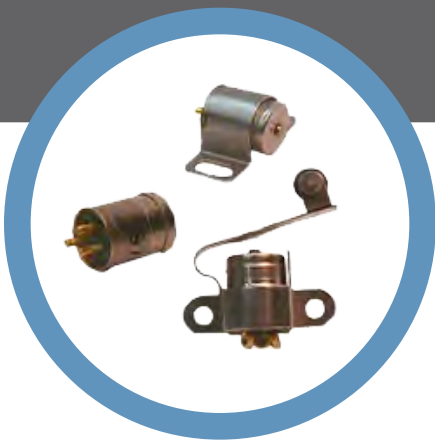

KLIXON® | AT Series

Snap Action Precision Position Switches

FEATURES

- Meet the demands of low-level current switching applications
- Various mechanical and electrical configurations available as standard or custom configurations
- Actuation plungers of various shapes and materials available
- Multi-pole switch package options
- Mounting via threaded brushings or side-plate design
- Wiring can be supplied as flying leads or via a variety of standard connectors

INTRODUCTION

The Klixon® AT series are our most popular family of precision hermetic switches because of their broad performance envelope, small size, and ability to be easily incorporated into a wide variety of packages. Klixon® AT series switches are available as basic switches, basic switches with mounting brackets and actuators, or as switch packages. Packages are formed by configuring various electrical terminations, actuator means and physical construction around one or more basic switches.

Within this family there are four basic switches: the AT, the 3AT, the 4AT, and the 10AT. Each has been optimized for particular performance characteristics and is capable of meeting the demands of low-level current switching applications.

<p>Standard AT Series</p>	<p>The AT basic switch is the standard device in the AT family, capable of switching up to 3 amps at 28 VDC into resistive loads. See the chart for inductive and lamp loads. Electrical life at these loads is 25K cycles, minimum. Lower currents extend life up to the minimum mechanical life of 100K cycles.</p>
<p>High Temperature 3AT Series</p>	<p>If your application requires a device which operates at higher ambient temperatures, then consider the 3AT. Electrical and mechanical life are the same, while the maximum current level is 1A at 28 VDC into resistive loads.</p>
<p>Low Temperature 4AT Series</p>	<p>This device is designed to operate at temperatures lower than the standard AT switch, ideal for space applications. Electrical life at 3A, 28VDC is 25K cycles for resistive loads.</p>
<p>High Amperage 10AT Series</p>	<p>Designed to operate at lower temperatures and higher current capability than the standard AT switch, the 10AT's maximum current has been extended to 4A at 28VDC (resistive), with an electrical life is 25K cycles and mechanical life is 50K cycles. 10AT's are on the military qualified parts list (MIL-S-8805).</p>





PERFORMANCE & ACTUATION CHARACTERISTICS CHART

		AT		3AT	4AT	10AT
Device Type		Standard		High Temperature	Low Temperature	High Amperage
Maximum Actuating Force (STP)		20 oz		20 oz	28 oz	30 oz
Minimum Release Force (STP)		4 oz		4 oz	1 oz	1 oz
Maximum Pretravel		0.009"		0.009"	0.009"	0.009"
Maximum Movement Differential		0.003"		0.003"	0.003"	0.003"
Minimum Overtravel		0.002"		0.002"	0.002"	0.002"
Overtravel Stop		No		No	No	No
Maximum Force on Actuator		5 lb		5 lb	5 lb	5 lb
Current Ratings in Amps (28VDC)	Resistance	3	1	1	3	4
	Inductive	1	½	½	1	1
	Lamp	1	½	½	1	2
Minimum Life @ Rated Load		25K	50K	25K	25K	25K
Minimum Mechanical Life Cycles		100K		100K	50K	50K
Ambient Temperature Range		-65°F to 275°F (-53.8°C to 135°C)		-65°F to 450°F (-53.8°C to 232.2°C)	-275°F to 275°F (-170.5°C to 135°C)	-85°F to 275°F (-65°C to 135°C)
Dielectric Strength Terminal to Case Terminal to Terminal		1000 VRMS 800 VRMS		500 VRMS 500 VRMS	1000 VRMS 800 VRMS	1000 VRMS 800 VRMS
Max Leakage		1 x 10 ⁻⁸ Std. cc He/Sec @ 1 atmosphere differential				
Shock Resistance		200G, 6 ms sawtooth				
Vibration Resistance		65G, 10-2000Hz, .5DA or 65GTMS				
Insulation Resistance @ 500VDC		100 Megohms				
Voltage Drop @ 1 amp		0.04		0.12	0.04	0.04
SEAL (MIL-S-8805)		Design enclosure 5				
Backfill		Dry nitrogen with 10% helium				

NOTE FOR DRAWINGS :

1. Because of restricted space we can only show a small percentage of our switch packages and dimensional drawings. Please contact the factory if you do not see the solution you need, or if you require more detailed envelope drawings.
2. Unless otherwise noted, standard leads are AWG #20 per MIL-W-22759/9.
3. All exposed materials on packaged designs are corrosion resistant steel with the exception of the side plates on Style 7 switches which are anodized aluminum alloy.
4. All hardware provided is corrosion resistant steel.

BASIC "AT", BRACKET/FLANGE/THREADS, 1 POLE

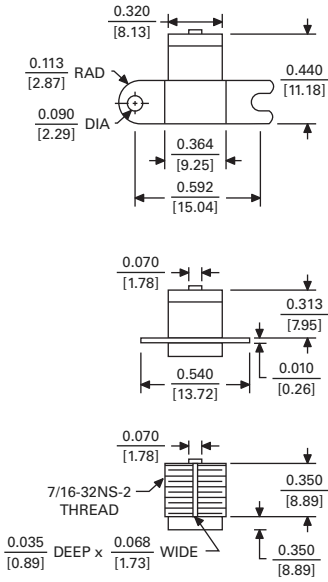

AT104-01, 10AT17-03-10, 10AT15-03-10

Bracket
Flange
Threads

Actuating Force (max)
Release Force (max)
Pretravel (max)
Movement Diff. (max)
Overtravel (min)
Positive Overtravel Stop
Max Force on Actuator
Approx Weight (no leads)

Basic Switch & Actuator/Body Style			
AT373	3AT46	4AT48	10AT15
std	hi temp	low temp	hi amp
20 oz	20 oz	28 oz	30 oz
1 oz	1 oz	1 oz	4 oz
	.009" (0.23mm)		.005" (0.13mm)
	.003" (0.08mm)		
No	No	No	No
5 lb	5 lb	5 lb	5 lb
0.15 oz	0.15 oz	0.15 oz	0.15 oz

3AT47 - 1 3 - 6

Operation	
0	SPDT
1	SPST, N.C.
2	SPST, N.O.

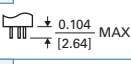
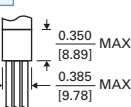
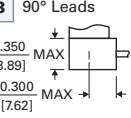
Termination	
1	Solder Ons 
2	Parallel Leads 
3	90° Leads 

Lead Length	
1	6" (153mm)
2	12" (305mm)
3	18" (458mm)
4	24" (610mm)
5	30" (762mm)
6	36" (915mm)
7	42" (1067mm)
8	48" (1220mm)
9	60" (1524mm)
10	72" (1829mm)

BASIC "AT", RIGHT HAND ACTUATOR, 1 POLE

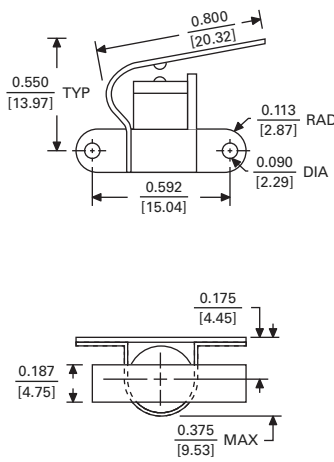

Actuating Force (max)
Release Force (max)
Pretravel (max)
Movement Diff. (max)
Overtravel (min)
Positive Overtravel Stop
Max Force on Actuator
Approx Weight (no leads)

Basic Switch & Actuator/Body Style			
AT289	3AT40	4AT43	10AT27
std	hi temp	low temp	hi amp
24 oz	24 oz	35 oz	35 oz
1 oz	1 oz	1 oz	4 oz
	.250" (6.35mm)		
	.050" (1.27mm)		
	.015" (0.38mm)		
Yes	Yes	Yes	Yes
5 lb	5 lb	5 lb	5 lb
0.18 oz	0.18 oz	0.18 oz	0.18 oz

AT289 - 2 2 - 5

Operation	
0	SPDT
1	SPST, N.C.
2	SPST, N.O.

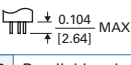
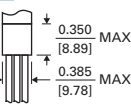
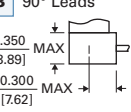
Termination	
1	Solder Ons 
2	Parallel Leads 
3	90° Leads 

Lead Length	
1	6" (153mm)
2	12" (305mm)
3	18" (458mm)
4	24" (610mm)
5	30" (762mm)
6	36" (915mm)
7	42" (1067mm)
8	48" (1220mm)
9	60" (1524mm)
10	72" (1829mm)

BASIC "AT", LEFT HAND ACTUATOR, 1 POLE

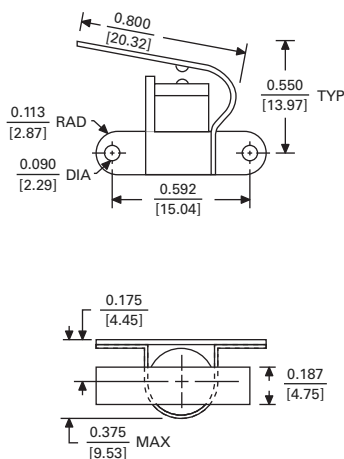

Actuating Force (max)
Release Force (max)
Pretravel (max)
Movement Diff. (max)
Overtravel (min)
Positive Overtravel Stop
Max Force on Actuator
Approx Weight (no leads)

Basic Switch & Actuator/Body Style			
AT290	3AT41	4AT44	10AT28
std	hi temp	low temp	hi amp
24 oz	24 oz	35 oz	35 oz
1 oz	1 oz	1 oz	4 oz
	.250" (6.35mm)		
	.050" (1.27mm)		
	.015" (0.38mm)		
Yes	Yes	Yes	Yes
5 lb	5 lb	5 lb	5 lb
0.18 oz	0.18 oz	0.18 oz	0.18 oz

AT290 - 2 2 - 4

Operation	
0	SPDT
1	SPST, N.C.
2	SPST, N.O.

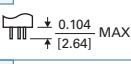
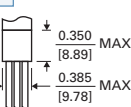
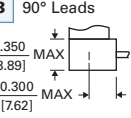
Termination	
1	Solder Ons 
2	Parallel Leads 
3	90° Leads 

Lead Length	
1	6" (153mm)
2	12" (305mm)
3	18" (458mm)
4	24" (610mm)
5	30" (762mm)
6	36" (915mm)
7	42" (1067mm)
8	48" (1220mm)
9	60" (1524mm)
10	72" (1829mm)

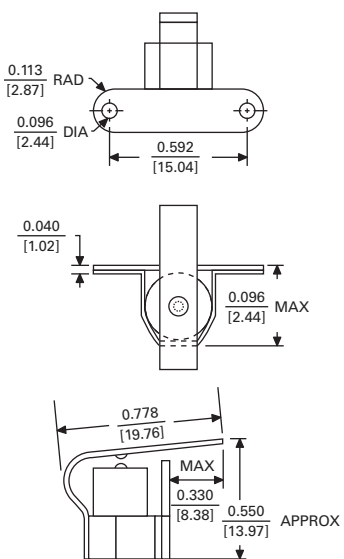

BASIC "AT", CENTRAL ACTUATOR, 1 POLE

3AT53 - 2 1 - 4

Basic Switch & Actuator/Body Style				
AT294	3AT53	4AT50	10AT29	
std	hi temp	low temp	hi amp	
Actuating Force (max)	24 oz	24 oz	35 oz	35 oz
Release Force (max)	1 oz	1 oz	1 oz	4 oz
Pretravel (max)	.250" (6.35mm)			
Movement Diff. (max)	.050" (1.27mm)			
Overtravel (min)	.015" (0.38mm)			
Positive Overtravel Stop	Yes	Yes	Yes	Yes
Max Force on Actuator	5 lb	5 lb	5 lb	5 lb
Approx Weight (no leads)	0.2 oz	0.2 oz	0.2 oz	0.2 oz

Operation	
0	SPDT
1	SPST, N.C.
2	SPST, N.O.

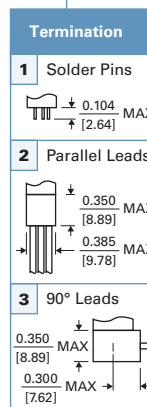

Lead Length	
1	6" (153mm)
2	12" (305mm)
3	18" (458mm)
4	24" (610mm)
5	30" (762mm)
6	36" (915mm)
7	42" (1067mm)
8	48" (1220mm)
9	60" (1524mm)
10	72" (1829mm)

Actuating Force (max)
Release Force (max)
Pretravel (max)
Movement Diff. (max)
Overtravel (min)
Positive Overtravel Stop
Max Force on Actuator
Approx Weight (no leads)

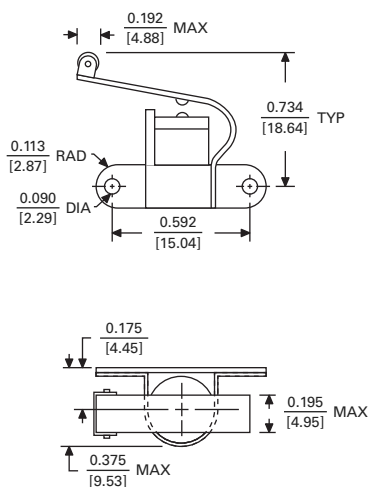

BASIC "AT", LEFT HAND ACTUATOR, 1 POLE

AT292 - 1 2 - 5

Basic Switch & Actuator/Body Style				
AT292	3AT43	4AT46	10AT31	
std	hi temp	low temp	hi amp	
Actuating Force (max)	24 oz	24 oz	35 oz	35 oz
Release Force (max)	1 oz	1 oz	1 oz	4 oz
Pretravel (max)	.250" (6.35mm)			
Movement Diff. (max)	.050" (1.27mm)			
Overtravel (min)	.015" (0.38mm)			
Positive Overtravel Stop	Yes	Yes	Yes	Yes
Max Force on Actuator	5 lb	5 lb	5 lb	5 lb
Approx Weight (no leads)	0.18 oz	0.18 oz	0.18 oz	0.18 oz

Operation	
0	SPDT
1	SPST, N.C.
2	SPST, N.O.

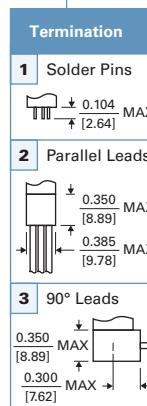

Lead Length	
1	6" (153mm)
2	12" (305mm)
3	18" (458mm)
4	24" (610mm)
5	30" (762mm)
6	36" (915mm)
7	42" (1067mm)
8	48" (1220mm)
9	60" (1524mm)
10	72" (1829mm)

Actuating Force (max)
Release Force (max)
Pretravel (max)
Movement Diff. (max)
Overtravel (min)
Positive Overtravel Stop
Max Force on Actuator
Approx Weight (no leads)

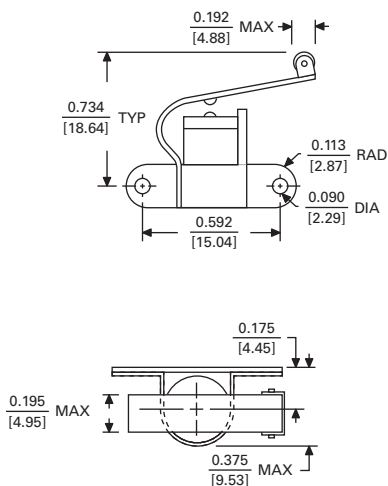

BASIC "AT", RIGHT HAND ACTUATOR, 1 POLE

AT291 - 2 2 - 2

Basic Switch & Actuator/Body Style				
AT291	3AT42	4AT45	10AT30	
std	hi temp	low temp	hi amp	
Actuating Force (max)	24 oz	24 oz	35 oz	35 oz
Release Force (max)	1 oz	1 oz	1 oz	4 oz
Pretravel (max)	.250" (6.35mm)			
Movement Diff. (max)	.050" (1.27mm)			
Overtravel (min)	.015" (0.38mm)			
Positive Overtravel Stop	Yes	Yes	Yes	Yes
Max Force on Actuator	5 lb	5 lb	5 lb	5 lb
Approx Weight (no leads)	0.2 oz	0.2 oz	0.2 oz	0.2 oz

Operation	
0	SPDT
1	SPST, N.C.
2	SPST, N.O.

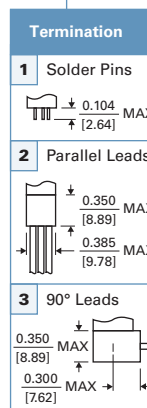

Lead Length	
1	6" (153mm)
2	12" (305mm)
3	18" (458mm)
4	24" (610mm)
5	30" (762mm)
6	36" (915mm)
7	42" (1067mm)
8	48" (1220mm)
9	60" (1524mm)
10	72" (1829mm)

Actuating Force (max)
Release Force (max)
Pretravel (max)
Movement Diff. (max)
Overtravel (min)
Positive Overtravel Stop
Max Force on Actuator
Approx Weight (no leads)

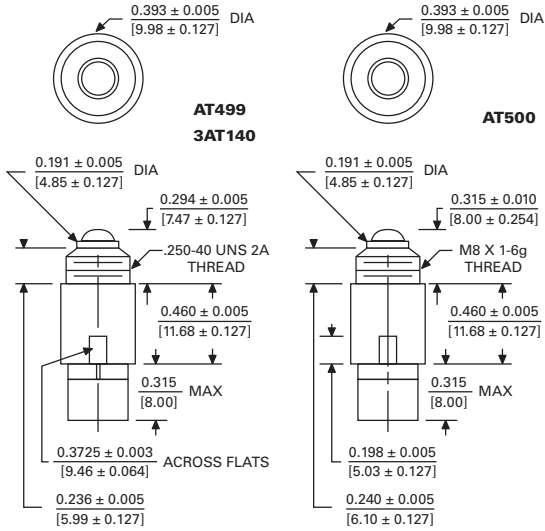

THREADED HEX BODY, FLAT & ROUND PLUNGER, 1 POLE

AT500 - 2 2 - 10

Basic Switch & Actuator/Body Style			Operation	Termination	Lead Length
AT499	3AT140	AT500	0 SPDT	1 Solder Pins ± 0.104 MAX [2.64]	1 6" (153mm)
<i>std</i>	<i>hi temp</i>	<i>std</i>	1 SPST, N.C.	2 Parallel Leads ± 0.350 MAX [8.89] ± 0.385 MAX [9.78]	2 12" (305mm)
Actuating Force (max)			2 SPST, N.O.	3 90° Leads ± 0.350 MAX [8.89] ± 0.300 MAX [7.62]	3 18" (458mm)
Release Force (max)					4 24" (610mm)
Pretravel (max)					5 30" (762mm)
Movement Diff. (max)					6 36" (915mm)
Overtravel (min)					7 42" (1067mm)
Positive Overtravel Stop					8 48" (1220mm)
Max Force on Actuator					9 60" (1524mm)
Approx Weight (no leads)					10 72" (1829mm)

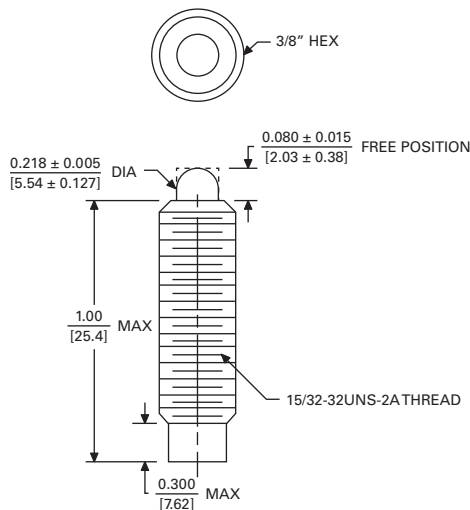

THREADED HEX BODY, FLAT & ROUND PLUNGER, 1 POLE

10AT384 - 2 2 - 10

Basic Switch & Actuator/Body Style			Operation	Termination	Lead Length
<i>Flat Plunger</i>	AT414	3AT141	0 SPDT	1 Solder Pins ± 0.104 MAX [2.64]	1 6" (153mm)
<i>Round Plunger</i>	AT415	3AT142	1 SPST, N.C.	2 Parallel Leads ± 0.350 MAX [8.89] ± 0.385 MAX [9.78]	2 12" (305mm)
	<i>std</i>	<i>hi temp</i>	2 SPST, N.O.	3 90° Leads ± 0.350 MAX [8.89] ± 0.300 MAX [7.62]	3 18" (458mm)
Actuating Force (max)					4 24" (610mm)
Release Force (max)					5 30" (762mm)
Pretravel (max)					6 36" (915mm)
Movement Diff. (max)					7 42" (1067mm)
Overtravel (min)					8 48" (1220mm)
Positive Overtravel Stop					9 60" (1524mm)
Max Force on Actuator					10 72" (1829mm)
Approx Weight (no leads)					

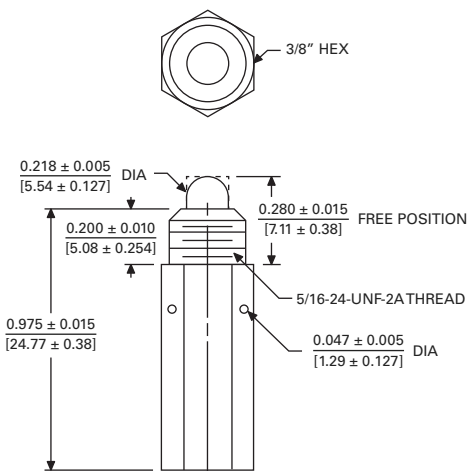

THREADED HEX BODY, FLAT & ROUND PLUNGER, 1 POLE

AT394 - 0 3 - 3

Basic Switch & Actuator/Body Style			Operation	Termination	Lead Length
<i>Flat Plunger</i>	AT393	3AT143	0 SPDT	1 Solder Pins ± 0.104 MAX [2.64]	1 6" (153mm)
<i>Round Plunger</i>	AT394	3AT144	1 SPST, N.C.	2 Parallel Leads ± 0.350 MAX [8.89] ± 0.385 MAX [9.78]	2 12" (305mm)
	<i>std</i>	<i>hi temp</i>	2 SPST, N.O.	3 90° Leads ± 0.350 MAX [8.89] ± 0.300 MAX [7.62]	3 18" (458mm)
Actuating Force (max)					4 24" (610mm)
Release Force (max)					5 30" (762mm)
Pretravel (max)					6 36" (915mm)
Movement Diff. (max)					7 42" (1067mm)
Overtravel (min)					8 48" (1220mm)
Positive Overtravel Stop					9 60" (1524mm)
Max Force on Actuator					10 72" (1829mm)
Approx Weight (no leads)					

THREADED HEX BODY, FLAT & ROUND PLUNGER, 1 POLE

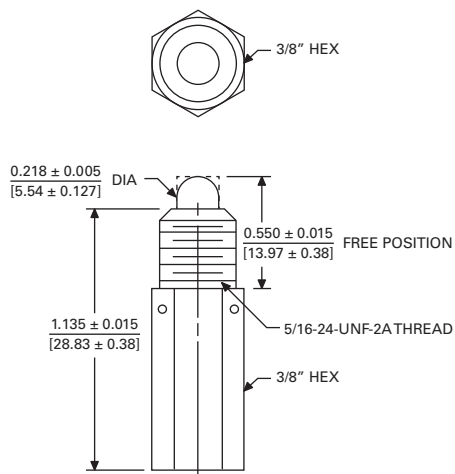

10AT364 - 0 3 - 10

	Basic Switch & Actuator/Body Style			Operation	Termination	Lead Length
	AT395	3AT145	10AT363			
<i>Flat Plunger</i>	AT395	3AT145	10AT363	0 SPDT 1 SPST, N.C. 2 SPST, N.O.	1 Solder Pins ↓ ± 0.104 MAX ↑ [2.64] 2 Parallel Leads ↓ ± 0.350 MAX [8.89] ↑ ± 0.385 MAX [9.78] 3 90° Leads ↓ ± 0.350 MAX [8.89] ↑ ± 0.300 MAX [7.62]	1 6" (153mm) 2 12" (305mm) 3 18" (458mm) 4 24" (610mm) 5 30" (762mm) 6 36" (915mm) 7 42" (1067mm) 8 48" (1220mm) 9 60" (1524mm) 10 72" (1829mm)
<i>Round Plunger</i>	AT396	3AT146	10AT364			
<i>Actuating Force (max)</i>	20 oz		30 oz			
<i>Release Force (max)</i>	1 oz		4 oz			
<i>Pretravel (max)</i>	.010" (.254mm)					
<i>Movement Diff. (max)</i>	.005" (.127mm)					
<i>Overtravel (min)</i>	.125" (3.18mm)					
<i>Positive Overtravel Stop</i>	Yes		Yes			
<i>Max Force on Actuator</i>	20 lb		20 lb			
<i>Approx Weight (no leads)</i>	0.6 oz		0.6 oz			

THREADED HEX BODY, FLAT PLUNGER, 1 POLE

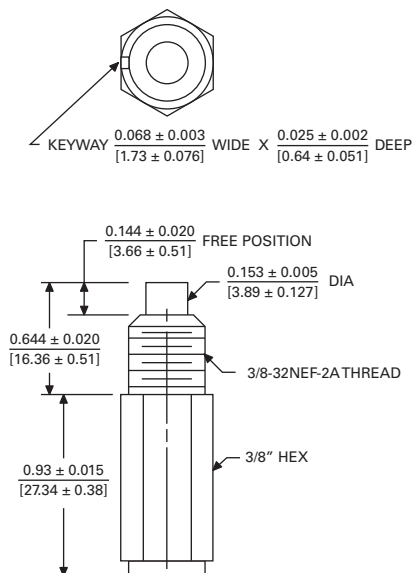

AT268 - 2 2 - 2

	Basic Switch & Actuator/Body Style			Operation	Termination	Lead Length
	AT268	3AT138	10AT7			
<i>Actuating Force (max)</i>	104 oz			0 SPDT 1 SPST, N.C. 2 SPST, N.O.	1 Solder Pins ↓ ± 0.104 MAX ↑ [2.64] 2 Parallel Leads ↓ ± 0.350 MAX [8.89] ↑ ± 0.385 MAX [9.78] 3 90° Leads ↓ ± 0.350 MAX [8.89] ↑ ± 0.300 MAX [7.62]	1 6" (153mm) 2 12" (305mm) 3 18" (458mm) 4 24" (610mm) 5 30" (762mm) 6 36" (915mm) 7 42" (1067mm) 8 48" (1220mm) 9 60" (1524mm) 10 72" (1829mm)
<i>Release Force (max)</i>	24 oz					
<i>Plunger Seal / MIL-S-8805</i>	Yes					
<i>Pretravel (max)</i>	.010" (.254mm)					
<i>Movement Diff. (max)</i>	.005" (.127mm)					
<i>Overtravel (min)</i>	.060" (1.52mm)					
<i>Positive Overtravel Stop</i>	Yes					
<i>Max Force on Actuator</i>	20 lb					
<i>Approx Weight (no leads)</i>	0.5 oz					

THREADED HEX BODY, ROUND PLUNGER, 1 POLE

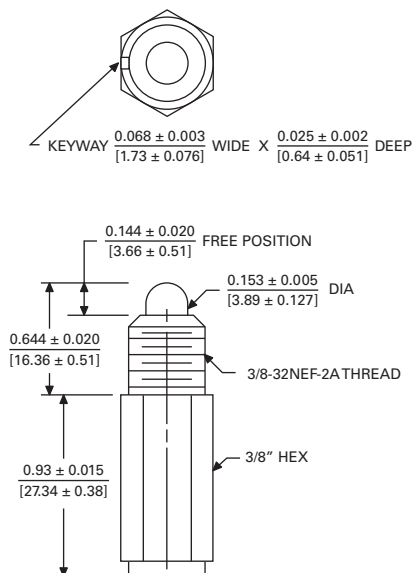

AT269 - 2 2 - 2

	Basic Switch & Actuator/Body Style			Operation	Termination	Lead Length
	AT269	3AT139	10AT76			
<i>Actuating Force (max)</i>	104 oz			0 SPDT 1 SPST, N.C. 2 SPST, N.O.	1 Solder Pins ↓ ± 0.104 MAX ↑ [2.64] 2 Parallel Leads ↓ ± 0.350 MAX [8.89] ↑ ± 0.385 MAX [9.78] 3 90° Leads ↓ ± 0.350 MAX [8.89] ↑ ± 0.300 MAX [7.62]	1 6" (153mm) 2 12" (305mm) 3 18" (458mm) 4 24" (610mm) 5 30" (762mm) 6 36" (915mm) 7 42" (1067mm) 8 48" (1220mm) 9 60" (1524mm) 10 72" (1829mm)
<i>Release Force (max)</i>	24 oz					
<i>Plunger Seal / MIL-S-8805</i>	Yes					
<i>Pretravel (max)</i>	.020" (.508mm)					
<i>Movement Diff. (max)</i>	.010" (.254mm)					
<i>Overtravel (min)</i>	.125" (3.18mm)					
<i>Positive Overtravel Stop</i>	Yes					
<i>Max Force on Actuator</i>	30 lb					
<i>Approx Weight (no leads)</i>	1.0 oz					

THREADED HEX BODY, PADDLE PLUNGER, 1 POLE

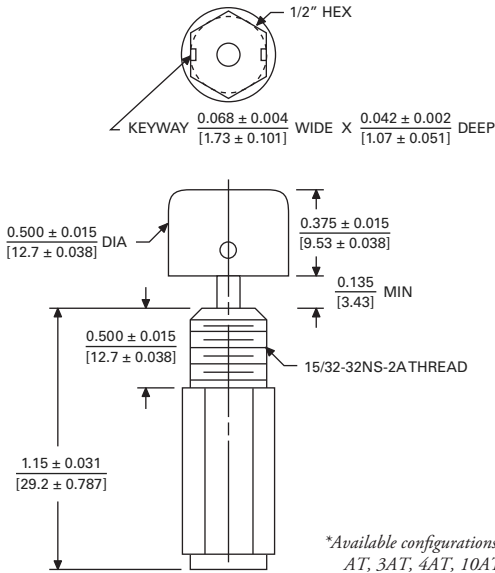

AT87 - 0 3 - 9

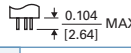
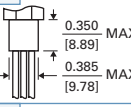
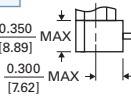
Basic Switch & Actuator/Body Style		Operation	Termination	Lead Length
AT224	10AT87	0 SPDT 1 SPST, N.C. 2 SPST, N.O.	1 Solder Pins  2 Parallel Leads  3 90° Leads 	1 6" (153mm) 2 12" (305mm) 3 18" (458mm) 4 24" (610mm) 5 30" (762mm) 6 36" (915mm) 7 42" (1067mm) 8 48" (1220mm) 9 60" (1524mm) 10 72" (1829mm)
<i>std</i>	<i>hi amp</i>			
104 oz	104 oz			
24 oz	24 oz			
Yes	Yes			
.020" (.508mm)	.010" (.254mm)			
.125" (3.18mm)	.125" (3.18mm)			
Yes	Yes			
30 lb	30 lb			
1.1 oz	1.1 oz			

THREADED, FLAT PLUNGER, 1 POLE

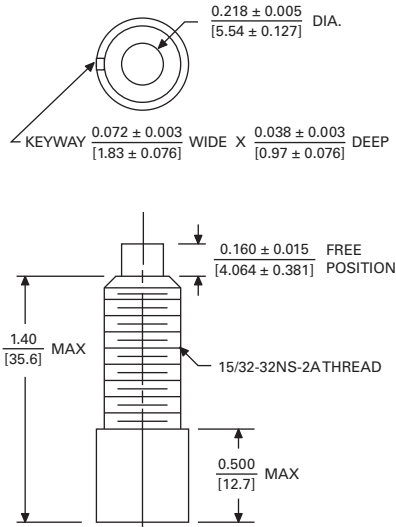

AT403 - 0 2 - 4

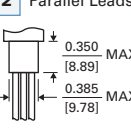
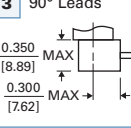
Basic Switch & Actuator/Body Style				Operation	Termination	Lead Length
AT400	10AT366	AT403	10AT369	0 SPDT 1 SPST, N.C. 2 SPST, N.O.	2 Parallel Leads  3 90° Leads 	1 6" (153mm) 2 12" (305mm) 3 18" (458mm) 4 24" (610mm) 5 30" (762mm) 6 36" (915mm) 7 42" (1067mm) 8 48" (1220mm) 9 60" (1524mm) 10 72" (1829mm)
<i>std</i>	<i>hi amp</i>	<i>std</i>	<i>hi amp</i>			
20 oz	30 oz	104 oz	112 oz			
1 oz	4 oz	24 oz	24 oz			
No	No	Yes	Yes			
.010" (.254mm)	.020" (.51mm)	.010" (.254mm)	.020" (.51mm)			
.005" (.127mm)	.005" (.127mm)	.005" (.127mm)	.005" (.127mm)			
.125" (3.18mm)	.125" (3.18mm)	.125" (3.18mm)	.125" (3.18mm)			
Yes	Yes	Yes	Yes			
30 lb	30 lb	30 lb	30 lb			
1.2 oz	1.2 oz	1.2 oz	1.2 oz			

THREADED, ROUND PLUNGER, 1 POLE

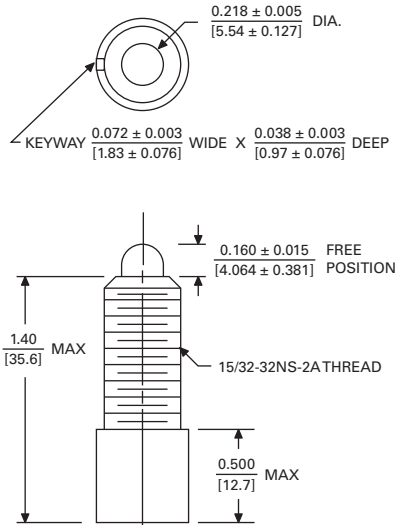

AT401 - 2 3 - 1

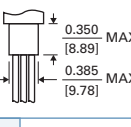
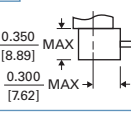
Basic Switch & Actuator/Body Style				Operation	Termination	Lead Length
AT401	10AT367	AT404	10AT370	0 SPDT 1 SPST, N.C. 2 SPST, N.O.	2 Parallel Leads  3 90° Leads 	1 6" (153mm) 2 12" (305mm) 3 18" (458mm) 4 24" (610mm) 5 30" (762mm) 6 36" (915mm) 7 42" (1067mm) 8 48" (1220mm) 9 60" (1524mm) 10 72" (1829mm)
<i>std</i>	<i>hi amp</i>	<i>std</i>	<i>hi amp</i>			
20 oz	30 oz	104 oz	112 oz			
1 oz	4 oz	24 oz	24 oz			
No	No	Yes	Yes			
.010" (.254mm)	.020" (.51mm)	.010" (.254mm)	.020" (.51mm)			
.005" (.127mm)	.005" (.127mm)	.005" (.127mm)	.005" (.127mm)			
.125" (3.18mm)	.125" (3.18mm)	.125" (3.18mm)	.125" (3.18mm)			
Yes	Yes	Yes	Yes			
30 lb	30 lb	30 lb	30 lb			
1.2 oz	1.2 oz	1.2 oz	1.2 oz			

THREADED, ROLLER PLUNGER, 1 POLE

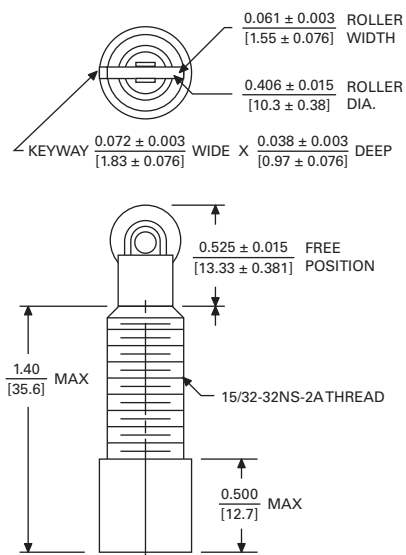

Actuating Force (max)
Release Force (max)
Plunger Seal / MIL-S-8805
Pretravel (max)
Movement Diff. (max)
Overtravel (min)
Positive Overtravel Stop
Max Force on Actuator
Approx Weight (no leads)

Basic Switch & Actuator/Body Style			
AT402	10AT368	AT405	10AT371
std	hi amp	std	hi amp
20 oz	30 oz	104 oz	112 oz
1 oz	4 oz	24 oz	24 oz
No	No	Yes	Yes
.010" (.254mm)	.020" (.51mm)	.005" (.127mm)	.005" (.127mm)
.125" (3.18mm)	.125" (3.18mm)		
Yes	Yes	Yes	Yes
30 lb	30 lb	30 lb	30 lb
1.3 oz	1.3 oz	1.3 oz	1.3 oz

10AT371 - 1 3 - 9

Operation	
0	SPDT
1	SPST, N.C.
2	SPST, N.O.

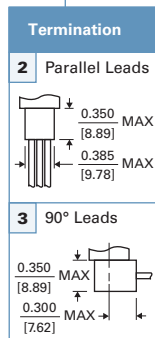

Lead Length	
1	6" (153mm)
2	12" (305mm)
3	18" (458mm)
4	24" (610mm)
5	30" (762mm)
6	36" (915mm)
7	42" (1067mm)
8	48" (1220mm)
9	60" (1524mm)
10	72" (1829mm)

* 3AT / 4AT versions available

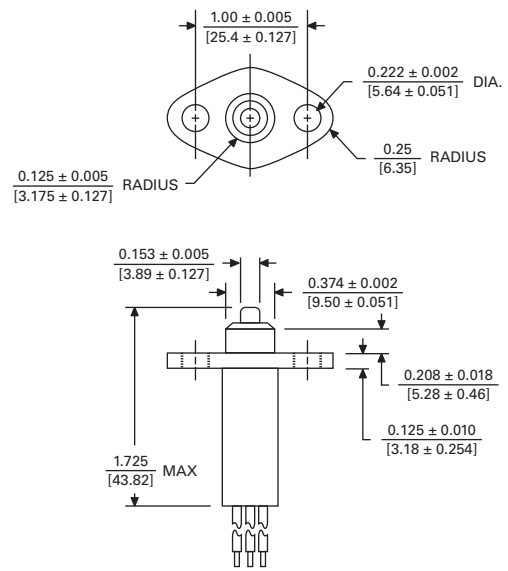

Actuating Force (max)
Release Force (max)
Plunger Seal / MIL-S-8805
Pretravel (max)
Movement Diff. (max)
Overtravel (min)
Positive Overtravel Stop
Max Force on Actuator
Approx Weight (no leads)

Basic Switch & Actuator/Body Style	
10AT376	
hi amp	
192 oz	
112 oz	
Yes	
.040" (1.02mm)	
.010" (.254mm)	
.125" (3.18mm)	
Yes	
30 lbs	
1.1 oz	

FLANGE MOUNT, SEALED PLUNGER, 1 POLE

10AT376 - 0 2 - 7

Operation	
0	SPDT
1	SPST, N.C.
2	SPST, N.O.

Termination	
2	Parallel Leads

Lead Length	
1	6" (153mm)
2	12" (305mm)
3	18" (458mm)
4	24" (610mm)
5	30" (762mm)
6	36" (915mm)
7	42" (1067mm)
8	48" (1220mm)
9	60" (1524mm)
10	72" (1829mm)

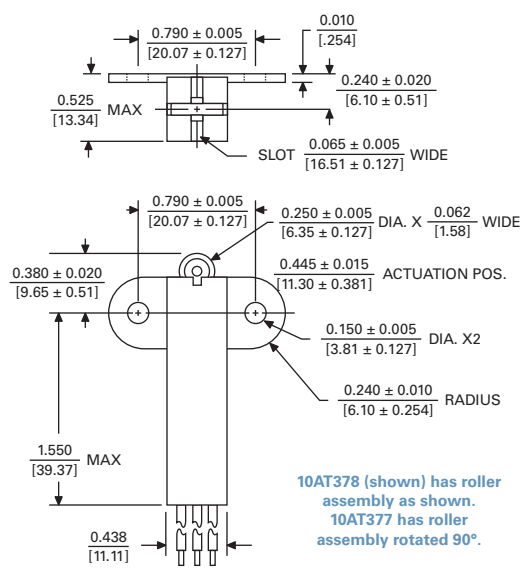

Actuating Force (max)
Release Force (max)
Plunger Seal / MIL-S-8805
Pretravel (max)
Movement Diff. (max)
Overtravel (min)
Positive Overtravel Stop
Max Force on Actuator
Approx Weight (no leads)

Basic Switch & Actuator/Body Style	
10AT377	10AT378
hi amp	hi amp
30 oz	30 oz
16 oz	16 oz
Yes	Yes
.040" (1.02mm)	
.010" (.254mm)	
.125" (3.18mm)	
Yes	Yes
30 lbs	30 lbs
1.2 oz	1.2 oz

FLANGE MOUNT, SEALED ROLLER PLUNGER, 1 POLE

10AT377 - 1 2 - 5

Operation	
0	SPDT
1	SPST, N.C.
2	SPST, N.O.

Termination	
2	Parallel Leads

Lead Length	
1	6" (153mm)
2	12" (305mm)
3	18" (458mm)
4	24" (610mm)
5	30" (762mm)
6	36" (915mm)
7	42" (1067mm)
8	48" (1220mm)
9	60" (1524mm)
10	72" (1829mm)

10AT378 (shown) has roller assembly as shown.
10AT377 has roller assembly rotated 90°.

FLANGE MOUNT, UNSEALED ROUND PLUNGER, 1 POLE

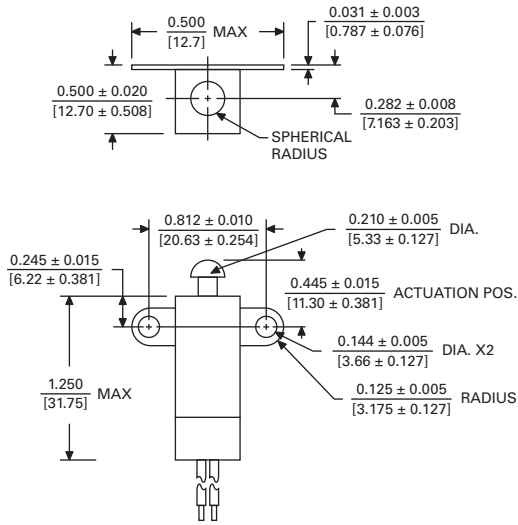

Actuating Force (max)
Release Force (max)
Plunger Seal / MIL-S-8805
Pretravel (max)
Movement Diff. (max)
Overtravel (min)
Positive Overtravel Stop
Max Force on Actuator
Approx Weight (no leads)

10AT379 - 1 2 - 9

Basic Switch & Actuator/Body Style	Operation	Termination	Lead Length
10AT379	0 SPDT	2 Parallel Leads	1 6" (153mm)
<i>hi amp</i>	1 SPST, N.C.		2 12" (305mm)
	2 SPST, N.O.		3 18" (458mm)
			4 24" (610mm)
			5 30" (762mm)
			6 36" (915mm)
			7 42" (1067mm)
			8 48" (1220mm)
			9 60" (1524mm)
			10 72" (1829mm)

THREADED, SEALED ROLLER PLUNGER, 2 POLE

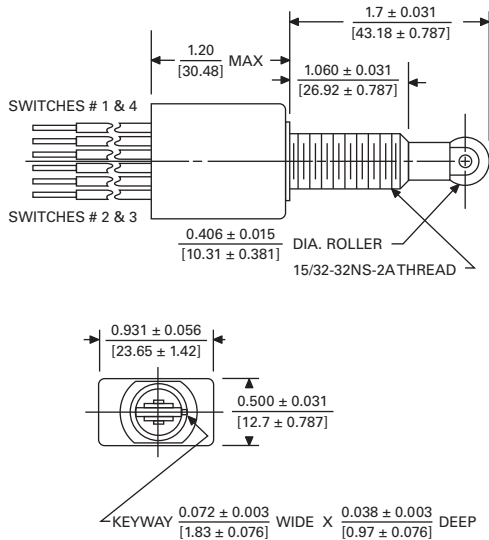

Actuating Force (max)
Release Force (max)
Plunger Seal / MIL-S-8805
Pretravel (max)
Movement Diff. (max)
Overtravel (min)
Positive Overtravel Stop
Max Force on Actuator
Approx Weight (no leads)

10AT373 - 3 3 - 1

Basic Switch & Actuator/Body Style	Operation	Termination	Lead Length
3AT147 10AT373	3 DPDT	2 Parallel Leads	1 6" (153mm)
<i>hi temp</i> <i>hi amp</i>	4 DPST, N.C.		2 12" (305mm)
	5 DPST, N.O.		3 18" (458mm)
	6 DPST, NC/NO		4 24" (610mm)
			5 30" (762mm)
			6 36" (915mm)
			7 42" (1067mm)
			8 48" (1220mm)
			9 60" (1524mm)
			10 72" (1829mm)

THREADED, SEALED FLAT PLUNGER, 2 POLE

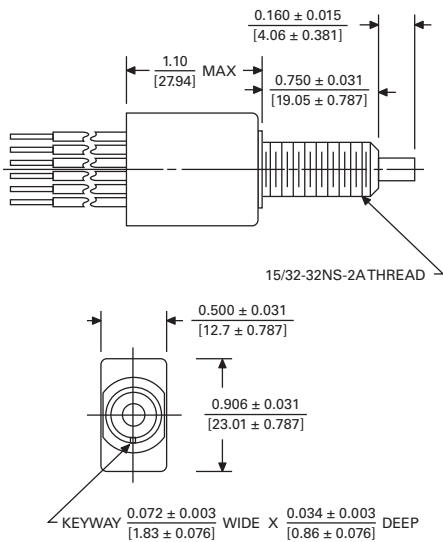

Actuating Force (max)
Release Force (max)
Plunger Seal / MIL-S-8805
Pretravel (max)
Movement Diff. (max)
Overtravel (min)
Positive Overtravel Stop
Max Force on Actuator
Approx Weight (no leads)

AT391 - 3 2 - 7

Basic Switch & Actuator/Body Style	Operation	Termination	Lead Length
AT391 3AT148 10AT358	3 DPDT	2 Parallel Leads	1 6" (153mm)
<i>std</i> <i>hi temp</i> <i>hi amp</i>	4 DPST, N.C.		2 12" (305mm)
	5 DPST, N.O.		3 18" (458mm)
	6 DPST, N.C./N.O.		4 24" (610mm)
			5 30" (762mm)
			6 36" (915mm)
			7 42" (1067mm)
			8 48" (1220mm)
			9 60" (1524mm)
			10 72" (1829mm)

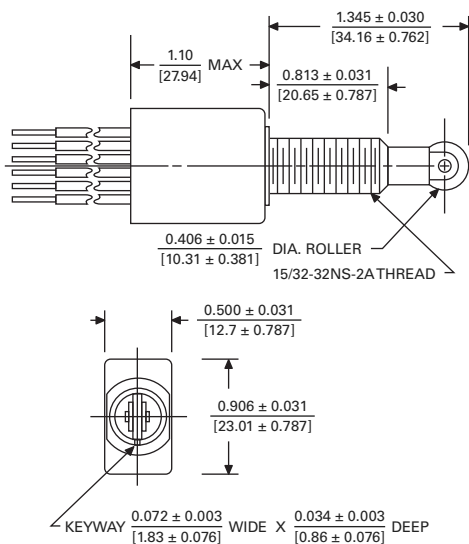

THREADED, SEALED ROLLER PLUNGER, 2 POLE

AT392 - 4 3 - 2

Basic Switch & Actuator/Body Style		Operation	Termination	Lead Length
AT392	10AT359	3 DPDT	2 Parallel Leads	1 6" (153mm)
<i>std</i>	<i>hi amp</i>	4 DPST, N.C.		2 12" (305mm)
Actuating Force (max)		5 DPST, N.O.		3 18" (458mm)
Release Force (max)		6 DPST, N.C./N.O.		4 24" (610mm)
Plunger Seal / MIL-S-8805				5 30" (762mm)
Pretravel (max)				6 36" (915mm)
Movement Diff. (max)			7 42" (1067mm)	
Overtravel (min)			8 48" (1220mm)	
Positive Overtravel Stop			9 60" (1524mm)	
Max Force on Actuator			10 72" (1829mm)	
Approx Weight (no leads)				

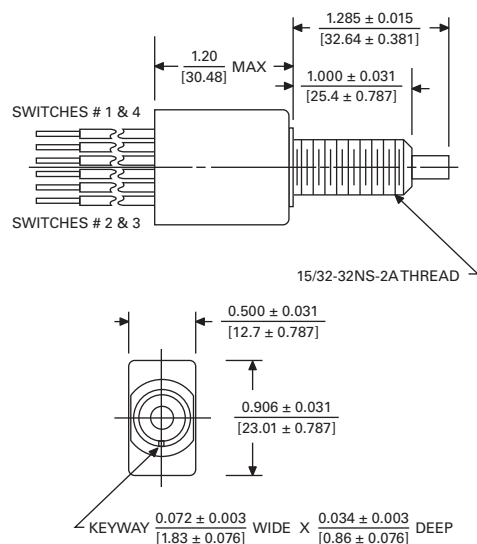

THREADED, SEALED FLAT PLUNGER, 2 POLE

AT406 - 6 2 - 6

Basic Switch & Actuator/Body Style		Operation	Termination	Lead Length
AT406	10AT372	3 DPDT	2 Parallel Leads	1 6" (153mm)
<i>hi amp</i>	<i>hi amp</i>	4 DPST, N.C.		2 12" (305mm)
Actuating Force (max)		5 DPST, N.O.		3 18" (458mm)
Release Force (max)		6 DPST, N.C./N.O.		4 24" (610mm)
Plunger Seal / MIL-S-8805				5 30" (762mm)
Pretravel (max)				6 36" (915mm)
Movement Diff. (max)			7 42" (1067mm)	
Overtravel (min)			8 48" (1220mm)	
Positive Overtravel Stop			9 60" (1524mm)	
Max Force on Actuator			10 72" (1829mm)	
Approx Weight (no leads)				

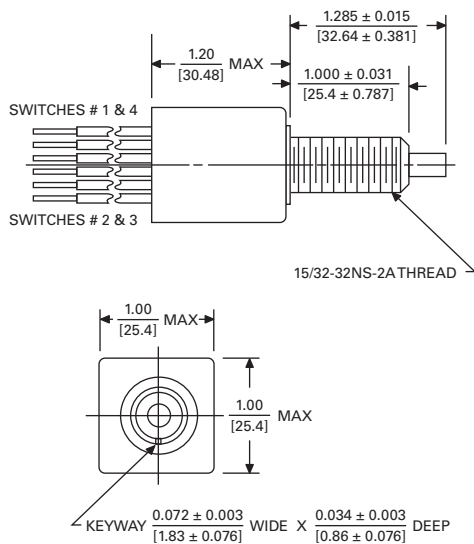

THREADED, SEALED FLAT PLUNGER, 3 OR 4 POLE

AT409 - 9 2 - 4

Basic Switch & Actuator/Body Style		Operation	Termination	Lead Length
AT409	10AT375	7 3PDT	2 Parallel Leads	1 6" (153mm)
<i>hi amp</i>	<i>hi amp</i>	8 3PST, N.C.		2 12" (305mm)
Actuating Force (max)		9 3PST, N.O.		3 18" (458mm)
Release Force (max)		10 4PDT		4 24" (610mm)
Plunger Seal / MIL-S-8805		11 4PST, N.C.		5 30" (762mm)
Pretravel (max)		12 4PST, N.O.		6 36" (915mm)
Movement Diff. (max)			7 42" (1067mm)	
Overtravel (min)			8 48" (1220mm)	
Positive Overtravel Stop			9 60" (1524mm)	
Max Force on Actuator			10 72" (1829mm)	
Approx Weight (no leads)				

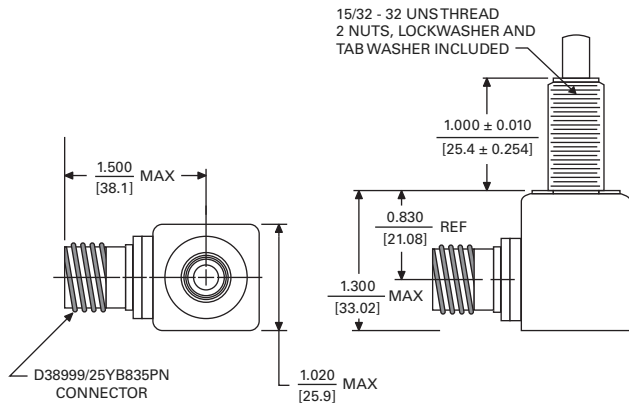

PLUNGER SWITCH, 1 POLE

10AT482 - 1

Basic Switch & Actuator/Body Style		Operation	
10AT482		1	SPST
<i>std</i>			
Actuating Force (max)	112 oz		
Release Force (min)	16 oz		
Pretravel (max)	.020" (.508mm)		
Movement Diff. (max)	.010" (.254mm)		
Overtravel (min)	.125" (3.18mm)		
Approx Weight (no leads)	4 oz		

Actuating Force (max)
Release Force (min)
Pretravel (max)
Movement Diff. (max)
Overtravel (min)
Approx Weight (no leads)

*Various connectors available

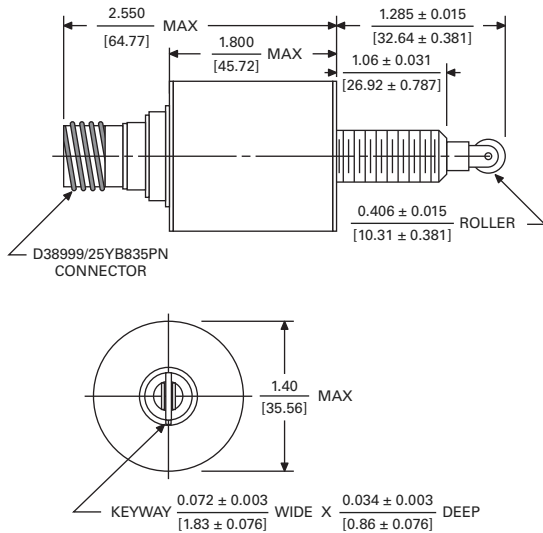

ROLLER PLUNGER SWITCH, 4 POLE

10AT490 - 1

Basic Switch & Actuator/Body Style		Operation	
10AT490		1	4PDT
<i>std</i>			
Actuating Force (max)	160 oz		
Release Force (min)	16 oz		
Pretravel (max)	.030" (.76mm)		
Movement Diff. (max)	.020" (.51mm)		
Overtravel (min)	.200" (5.08mm)		
Max Force on Actuator	30 lbs		
Approx Weight (no leads)	5.1 oz		

Actuating Force (max)
Release Force (min)
Pretravel (max)
Movement Diff. (max)
Overtravel (min)
Max Force on Actuator
Approx Weight (no leads)

*Various connectors available

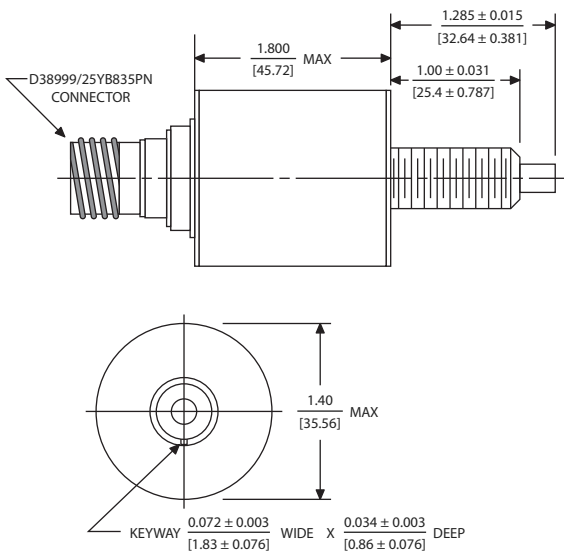

FLAT PLUNGER SWITCH, 4 POLE

10AT493 - 1

Basic Switch & Actuator/Body Style		Operation	
10AT493		1	4PDT
<i>std</i>			
Actuating Force (max)	160 oz		
Release Force (min)	16 oz		
Pretravel (max)	.030" (.76mm)		
Movement Diff. (max)	.020" (.51mm)		
Overtravel (min)	.200" (5.08mm)		
Max Force on Actuator	30 lbs		
Approx Weight (no leads)	5.1 oz		

Actuating Force (max)
Release Force (min)
Pretravel (max)
Movement Diff. (max)
Overtravel (min)
Max Force on Actuator
Approx Weight (no leads)

*Various connectors available

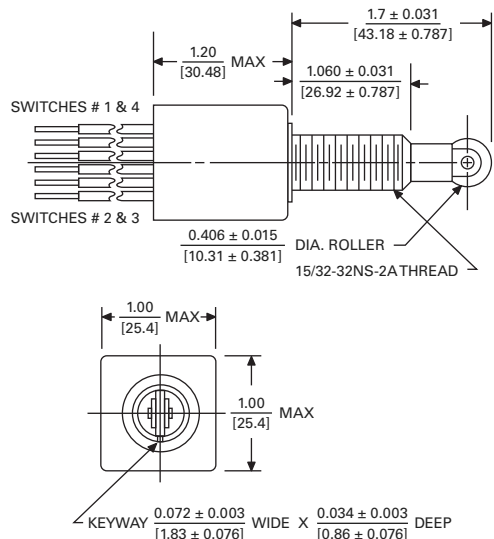

THREADED, SEALED ROLLER PLUNGER, 3 OR 4 POLE

AT408 - 7 3 - 1

Basic Switch & Actuator/Body Style		Operation	Termination	Lead Length
AT408	10AT374	7 3PDT	2 Parallel Leads	1 6" (153mm)
<i>hi amp</i>	<i>hi amp</i>	8 3PST, N.C.		2 12" (305mm)
160 oz	160 oz	9 3PST, N.O.		3 18" (458mm)
16 oz	16 oz	10 4PDT		4 24" (610mm)
Yes	Yes	11 4PST, N.C.		5 30" (762mm)
Plunger Seal / MIL-S-8805	Yes	12 4PST, N.O.	6 36" (915mm)	
Pretravel (max)	.030" (.76mm)		7 42" (1067mm)	
Movement Diff. (max)	.020" (.51mm)		8 48" (1220mm)	
Overtravel (min)	.200" (5.1mm)		9 60" (1524mm)	
Positive Overtravel Stop	Yes		10 72" (1829mm)	
Max Force on Actuator	30 lb			
Approx Weight (no leads)	3.4 oz			

Actuating Force (max)
Release Force (max)
Plunger Seal / MIL-S-8805
Pretravel (max)
Movement Diff. (max)
Overtravel (min)
Positive Overtravel Stop
Max Force on Actuator
Approx Weight (no leads)

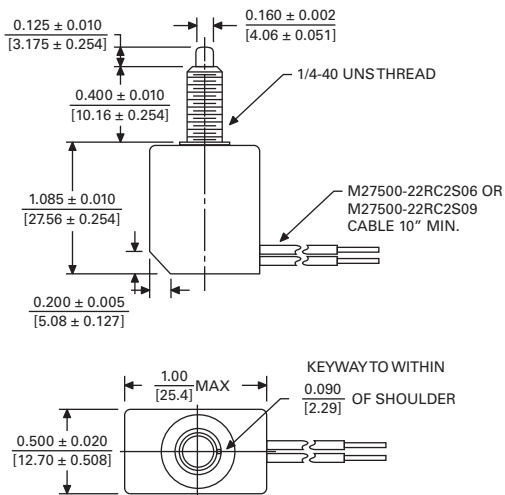

SMALLEST HERMETIC 2-POLE, PLUNGER (FLAT) SWITCH

10AT503 - 6 3 - 8

Basic Switch & Actuator/Body Style		Operation	Termination	Lead Length
3AT149	10AT503	3 DPDT	3 90° Leads	1 6" (153mm)
<i>hi temp</i>	<i>hi amp</i>	4 DPST, N.C.		2 12" (305mm)
64 oz		5 DPST, N.O.		3 18" (458mm)
16 oz	No	6 DPST, N.C. / N.O.	4 24" (610mm)	
Plunger Seal / MIL-S-8805			5 30" (762mm)	
Pretravel (max)	.010" (.254mm)		6 36" (915mm)	
Movement Diff. (max)	.010" (.254mm)		7 42" (1067mm)	
Overtravel (min)	.095" (2.41mm)		8 48" (1220mm)	
Max Force on Actuator	20 lbs		9 60" (1524mm)	
Approx Weight (no leads)	1.0 oz		10 72" (1829mm)	

Actuating Force (max)
Release Force (max)
Plunger Seal / MIL-S-8805
Pretravel (max)
Movement Diff. (max)
Overtravel (min)
Max Force on Actuator
Approx Weight (no leads)

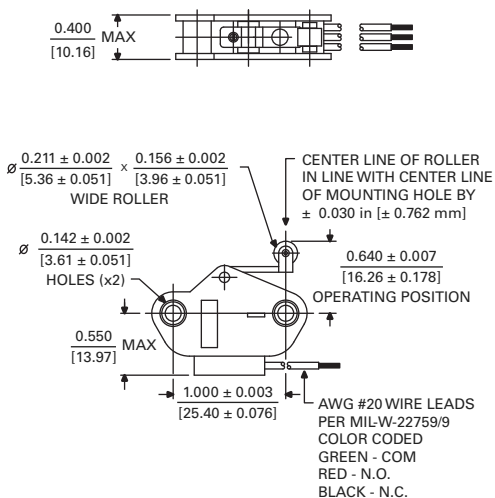

SIDE PLATE, RIGHT ARM, 1 POLE

AT355 - 2 3 - 8

Basic Switch & Actuator/Body Style			Operation	Termination	Lead Length
AT355	3AT150	10AT313	0 SPDT		1 6" (153mm)
<i>std</i>	<i>hi temp</i>	<i>hi amp</i>	1 SPST, N.C.		2 12" (305mm)
24 oz	4 oz		2 SPST, N.O.	3 18" (458mm)	
Release Force (max)				4 24" (610mm)	
Pretravel (max)	.040" (1.02mm)			5 30" (762mm)	
Movement Diff. (max)	.030" (.76mm)			6 36" (915mm)	
Overtravel (min)	.125" (3.18mm)			7 42" (1067mm)	
Positive Overtravel Stop	Yes			8 48" (1220mm)	
Max Force on Actuator	10 lbs			9 60" (1524mm)	
Approx Weight (no leads)	0.40 oz			10 72" (1829mm)	

Actuating Force (max)
Release Force (max)
Pretravel (max)
Movement Diff. (max)
Overtravel (min)
Positive Overtravel Stop
Max Force on Actuator
Approx Weight (no leads)

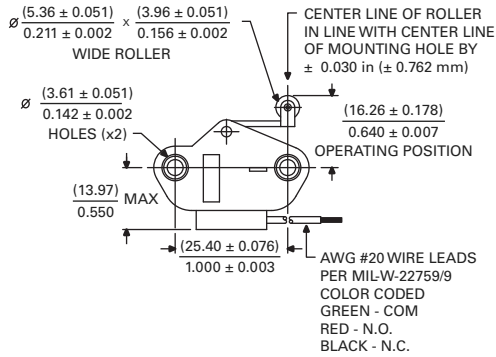
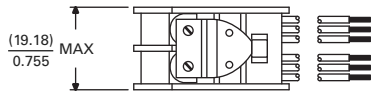

SIDE PLATE, RIGHT ARM, 2 POLE

10AT314 - 3 3 - 4

Basic Switch & Actuator/Body Style		Operation	Termination	Lead Length
AT356	10AT314			
<i>std</i>	<i>hi amp</i>			
Actuating Force (max)	48 oz	3 DPDT	3 90° Leads	1 6" (153mm)
Release Force (max)	4 oz	4 DPST, N.C.		2 12" (305mm)
Pretravel (max)	.040" (1.02mm)	5 DPST, N.O.		3 18" (458mm)
Movement Diff. (max)	.040" (1.02mm)	6 DPST, N.C / N.O.		4 24" (610mm)
Overtravel (min)	.125" (3.18mm)			5 30" (762mm)
Positive Overtravel Stop	Yes			6 36" (915mm)
Max Force on Actuator	10 lbs			7 42" (1067mm)
Approx Weight (no leads)	0.70 oz			8 48" (1220mm)
				9 60" (1524mm)
				10 72" (1829mm)

Actuating Force (max)
Release Force (max)
Pretravel (max)
Movement Diff. (max)
Overtravel (min)
Positive Overtravel Stop
Max Force on Actuator
Approx Weight (no leads)

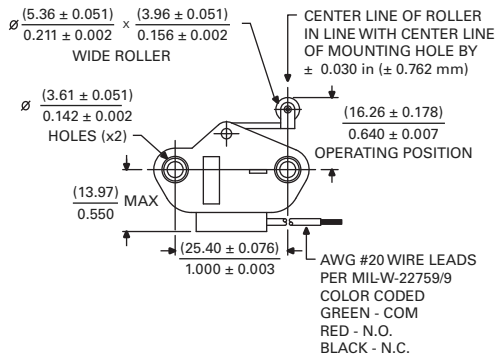
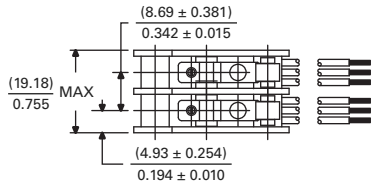

SIDE PLATE, RIGHT ARM, 2 POLE

10AT315 - 5 3 - 5

Basic Switch & Actuator/Body Style		Operation	Termination	Lead Length
AT357	10AT315			
<i>std</i>	<i>hi amp</i>			
Actuating Force (max)	24 oz	3 DPDT	3 90° Leads	1 6" (153mm)
Release Force (max)	4 oz	4 DPST, N.C.		2 12" (305mm)
Pretravel (max)	.040" (1.02mm)	5 DPST, N.O.		3 18" (458mm)
Movement Diff. (max)	.030" (.76mm)	6 DPST, N.C / N.O.		4 24" (610mm)
Overtravel (min)	.125" (3.18mm)			5 30" (762mm)
Positive Overtravel Stop	Yes			6 36" (915mm)
Max Force on Actuator	10 lbs			7 42" (1067mm)
Approx Weight (no leads)	0.80 oz			8 48" (1220mm)
				9 60" (1524mm)
				10 72" (1829mm)

Actuating Force (max)
Release Force (max)
Pretravel (max)
Movement Diff. (max)
Overtravel (min)
Positive Overtravel Stop
Max Force on Actuator
Approx Weight (no leads)

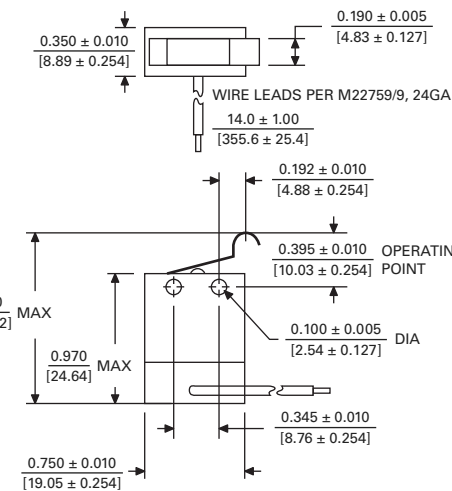

LEAF SPRING SWITCH, 1 POLE

10AT505 - 0 3 - 1

Basic Switch & Actuator/Body Style		Operation	Termination	Lead Length
3AT151	10AT505			
<i>hi temp</i>	<i>hi amp</i>			
Actuating Force (max)	20 oz	0 SPDT	3 90° Leads	1 6" (153mm)
Plunger Seal / MIL-S-8805	Yes			2 12" (305mm)
Pretravel (max)	.035" (.89mm)			3 18" (458mm)
Release Force (max)	4.0 oz			4 24" (610mm)
Movement Diff. (max)	.010" (.254mm)			5 30" (762mm)
Overtravel (min)	.065" (1.65mm)			6 36" (915mm)
Positive Overtravel Stop	Yes			7 42" (1067mm)
Max Force on Actuator	5 lb			8 48" (1220mm)
Approx Weight (no leads)	0.6 oz			9 60" (1524mm)
				10 72" (1829mm)

Actuating Force (max)
Plunger Seal / MIL-S-8805
Pretravel (max)
Release Force (max)
Movement Diff. (max)
Overtravel (min)
Positive Overtravel Stop
Max Force on Actuator
Approx Weight (no leads)

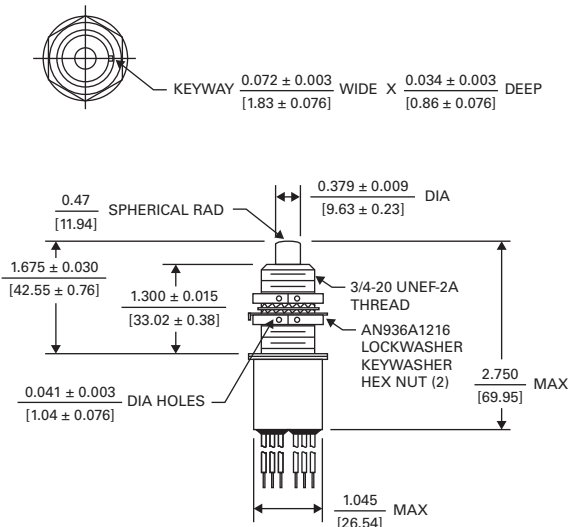

ROUNDED PLUNGER SWITCH, 2 POLE

3AT152 - 3 2 - 10

Basic Switch & Actuator/Body Style	Operation	Termination	Lead Length
3AT152			
High Temp (500°F)			
3 DPDT	2 Parallel Leads	1 6" (153mm)	
4 DPST, N.C.		2 12" (305mm)	
5 DPST, N.O.		3 18" (458mm)	
6 DPST, N.C / N.O.		4 24" (610mm)	
		5 30" (762mm)	
		6 36" (915mm)	
		7 42" (1067mm)	
		8 48" (1220mm)	
		9 60" (1524mm)	
		10 72" (1829mm)	

Actuating Force (max)
Release Force (min)
Pretravel (max)
Movement Diff. (max)
Overtravel (min)
Max Force on Actuator
Approx Weight (no leads)

Ref: MS24594-1 & M8805/41

*Various connectors available

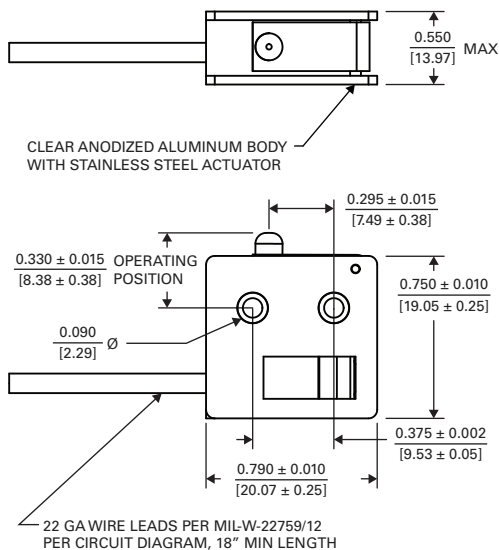

SIDE PLATE, 1 POLE

10AT511 - 0 3 - 10

Basic Switch & Actuator/Body Style	Operation	Termination	Lead Length
3AT137 10AT511			
hi temp hi amp			
0 SPDT	3 90° Leads	1 6" (153mm)	
1 SPST, N.C.		2 12" (305mm)	
2 SPST, N.O.		3 18" (458mm)	
		4 24" (610mm)	
		5 30" (762mm)	
		6 36" (915mm)	
		7 42" (1067mm)	
		8 48" (1220mm)	
		9 60" (1524mm)	
		10 72" (1829mm)	

Actuating Force (max)
Release Force (max)
Movement Diff. (max)
Overtravel (min)

Ref: MS27216 & M8805/8

*Various connectors available

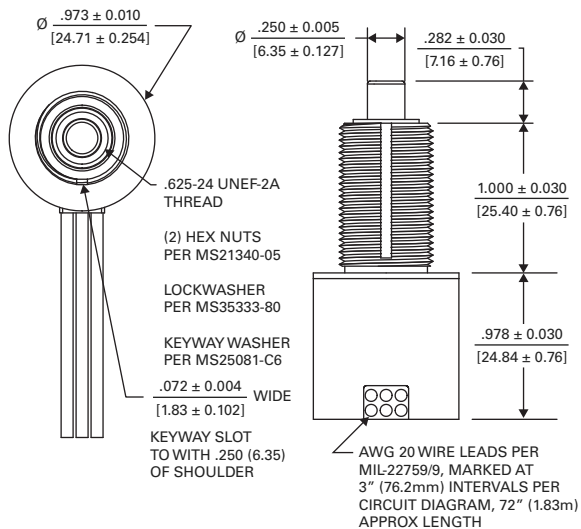

FLAT PLUNGER SWITCH, 2 POLE

10AT506 - 3 2 - 10

Basic Switch & Actuator/Body Style	Operation	Termination	Lead Length
10AT506			
hi temp			
3 DPDT	2 Parallel Leads	1 6" (153mm)	
4 DPST, N.C.		2 12" (305mm)	
5 DPST, N.O.		3 18" (458mm)	
6 DPST, N.C / N.O.	3 90° Angle Leads	4 24" (610mm)	
		5 30" (762mm)	
		6 36" (915mm)	
		7 42" (1067mm)	
		8 48" (1220mm)	
		9 60" (1524mm)	
		10 72" (1829mm)	

Actuating Force (max)
Release Force (min)
Pretravel (max)
Movement Diff. (max)
Overtravel (min)
Max Force on Actuator
Approx Weight (no leads)

Ref: M8805/80-01

*Various connectors available

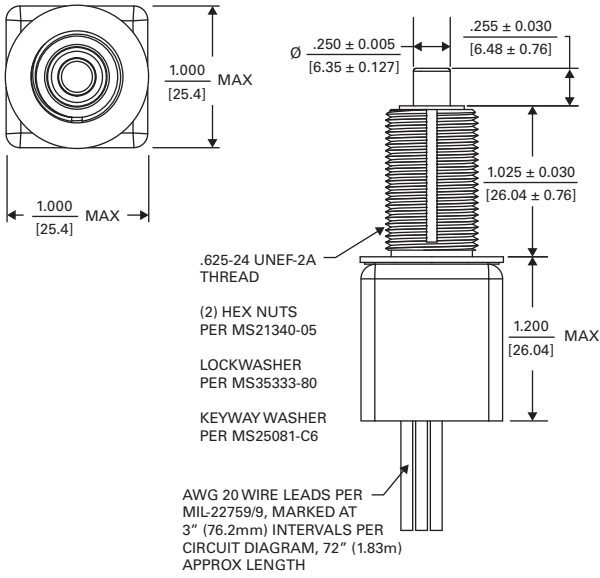

FLAT PLUNGER SWITCH, 3 or 4 POLE

10AT507 - 3 2 - 10

Basic Switch & Actuator/Body Style	Operation	Termination	Lead Length
10AT507	7 3PDT	2 Parallel Leads	1 6" (153mm)
<i>hi temp</i>	8 3PST, N.C.		2 12" (305mm)
	9 3PST, N.O.		3 18" (458mm)
	10 4PDT	3 90° Angle Leads	4 24" (610mm)
	11 4PST, N.C.		5 30" (762mm)
	12 4PST, N.O.		6 36" (915mm)
			7 42" (1067mm)
			8 48" (1220mm)
			9 60" (1524mm)
			10 72" (1829mm)

Actuating Force (max)
Release Force (min)
Pretravel (max)
Movement Diff. (max)
Overtravel (min)
Max Force on Actuator
Approx Weight (no leads)

Ref: M8805/80-04

*Various connectors available



KLIXON® | 10AT / 11AT / 12AT Series

Hermetic Control Switch Packages

INTRODUCTION

The Klixon® 10AT series are stainless steel, hermetic position limit switches, Klixon® 11AT and 12AT series are position control switches. All are ideal for extremely harsh and demanding environments as found in aircraft, military, aerospace, and aircraft engines applications. Klixon® precision hermetic position switches have been used for over 40 years in a wide range of applications, and can be found on virtually all commercial and military aircraft, as well as various space vehicles and satellites worldwide.

SPECIFICATIONS	
Current Rating (Resistance Inductive Lamp)	4 amps, 28VDC 1 amp, 28VDC 2 amp, 28VDC
Dielectric Strength	1050 volts (RMS) Terminal to Case, 800 volts (RMS) Terminal to Terminal
Life Cycles	25,000 cycles @ rated load, mechanical life of 100,000 cycles
Ambient Temperature Range	-85°F to +275°F (-65°C to +135°C)
Seal	Hermetic per MIL-PRF-8805, design enclosure 5
Max Leak Rate	1x10 ⁻⁸ C.C. std. HE/sec @ 1 ATM differential
Voltage Drop at 1 amp	0.040 volts max
Insulation	100 megaohms min
Vibration Resistance	65G, 10-2000Hz, .5 DA or 65 G RMS
Shock Resistance	200 G, 6 ms sawtooth

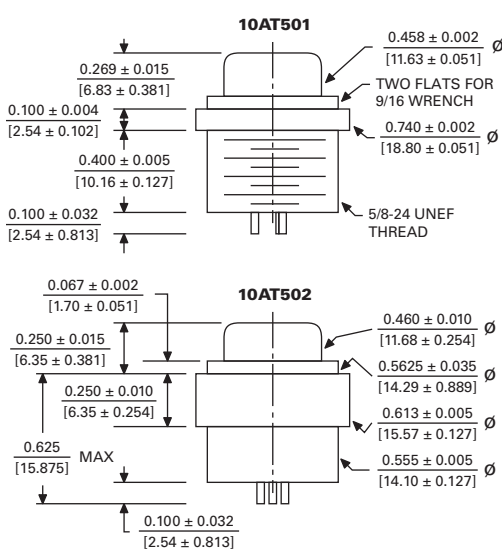

HERMETIC PUSH BUTTON MOMENTARY SWITCH

10AT502 - 1 - 0 2 - 10

Basic Switch & Actuator/Body Style	Button Color	Operation	Termination	Lead Length
10AT501	1 Red	0 SPDT	1 Solder Pins	1 6" (153mm)
10AT502	2 Black	1 SPDT, N.C.	2 Parallel Leads	2 12" (305mm)
	3 Gray	2 SPDT, N.O.		3 18" (458mm)
				4 24" (610mm)
				5 30" (762mm)
				6 36" (915mm)
				7 42" (1067mm)
				8 48" (1220mm)
				9 60" (1524mm)
				10 72" (1829mm)

Actuating Force (max) 40 oz (10AT501) / 24 oz (10AT502)

Pretravel (max) .040" (1.02mm)

Movement Diff. (max) .030" (.76mm)

Total Travel (min) .050" (1.27mm) / .125" (3.18mm)

Max Force on Actuator 10 lbs

Approx Weight 0.80 oz

Termination details: ± 0.104 MAX [2.64]

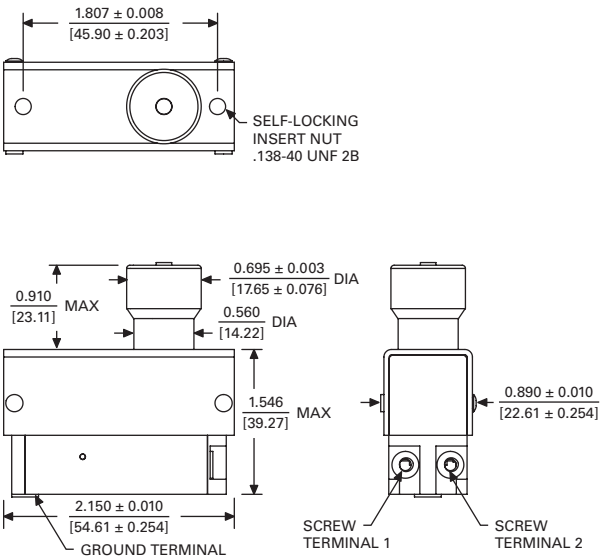

FOOT SWITCH (CONTROL SWITCH)

10AT504 - 5 1 - 5

Basic Switch & Actuator/Body Style	Operation	Termination	Lead Length
10AT504	5 DPST, N.O.	1 Screws	1 6" (153mm)
			2 12" (305mm)
			3 18" (458mm)
			4 24" (610mm)
			5 30" (762mm)
			6 36" (915mm)
			7 42" (1067mm)
			8 48" (1220mm)
			9 60" (1524mm)
			10 72" (1829mm)

Actuating Force (max) 112 to 176 oz
 Pretravel (max) .090" (2.29mm)
 Movement Diff. (max) .050" (1.27mm)
 Total Travel (min) .165" (4.19mm)
 Positive Overtravel Stop Yes
 Max Force on Actuator 20 lbs
 Approx Weight 0.9 oz

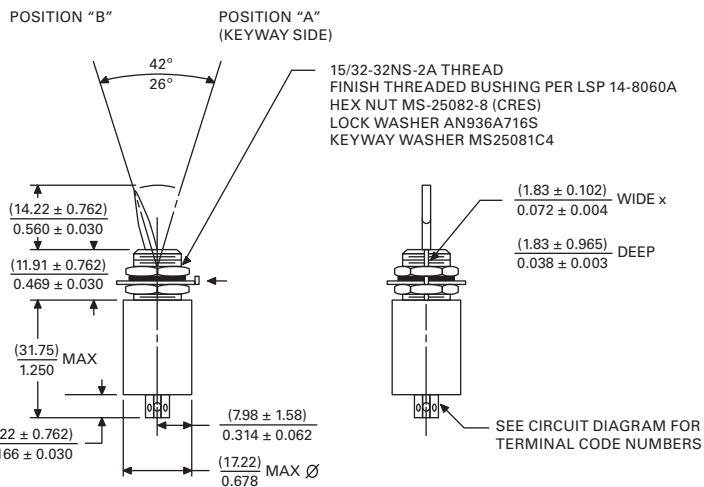

TOGGLE SWITCH

11AT1 - 0 1

Basic Switch & Actuator/Body Style	Operation	Termination
11AT1	0 SPDT	1 Solder Pins
	1 SPST, N.C.	
	2 SPST, N.O.	

Actuating Force 112 to 176 oz
 Current Capacity (28Vdc) 3.5A (res) / 1.5A (ind)

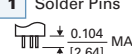

Toggle Position	Toggle Action	Circuit
POSITION "A"	MAINTAINED	1 2 3 ○ ○ ○
POSITION "B"	MAINTAINED	1 2 3 ○ ○ ○

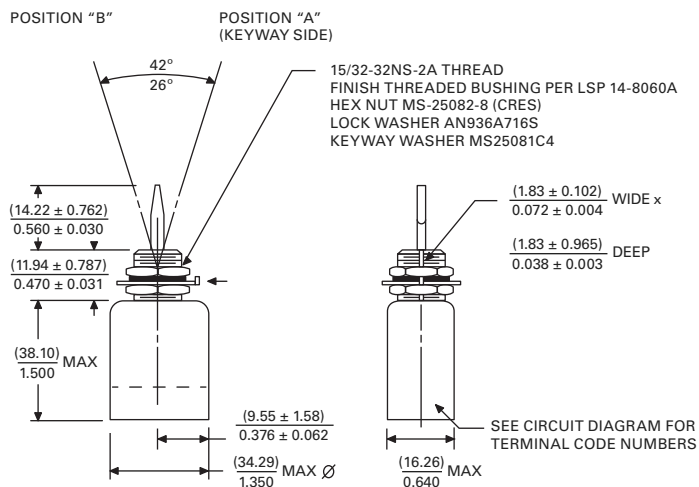

TOGGLE SWITCH, SP3T

12AT1 - 3 1

Basic Switch & Actuator/Body Style	Operation	Termination
12AT1	3 SP3T	1 Solder Pins

Actuating Force 16 to 64 oz
 Current Capacity (28Vdc) 3.5A (res) / 1.5A (ind)

Toggle Position	Toggle Action	Circuit
POSITION "A"	MAINTAINED	1 3 4 ○ ○ ○ 2
CENTER	MAINTAINED	1 3 4 ○ ○ ○ 2
POSITION "B"	MAINTAINED	1 3 4 ○ ○ ○ 2

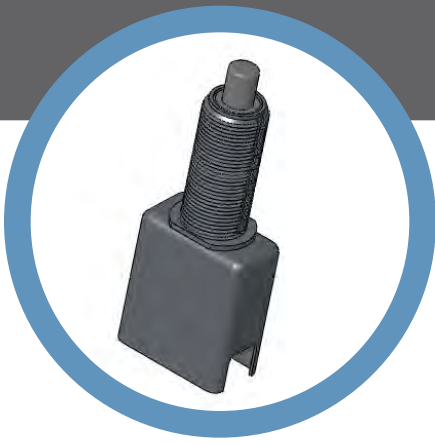

KLIXON® | Military Qualified 10AT Series

Snap Action Precision Position Switches

FEATURES

- Stainless steel, hermetic seal construction
- Rated up to 4 amps, 30VDC
- MIL-PRF-8805 qualified
- Various mounting configurations for custom applications
- Excellent shock and vibration resistance
- Distributor stock available

INTRODUCTION

The Klixon® 10AT series are hermetic position switches ideal for extremely harsh and demanding environments as found in aircraft, military, aerospace, and aircraft engines applications. Klixon precision hermetic position switches have been used for over 40 years in a wide range of applications, and can be found on virtually all commercial and military aircraft, as well as various space vehicles and satellites worldwide.

SPECIFICATIONS	
Current Rating, Resistance	4 amps, 28VDC
Current Rating, Inductive	1 amp, 28VDC
Current Rating, Lamp	2 amps, 28VDC
Dielectric Strength	1050 volts (RMS) Terminal to Case 800 volts (RMS) Terminal to Terminal
Life Cycles	25,000 cycles @ rated load, mechanical life of 100,000 cycles
Ambient Temperature Range	-85°F to +275°F (-65°C to +135°C)
Seal	Hermetic per MIL-PRF-8805, design enclosure 5
Max Leak Rate	1x10 ⁻⁸ C.C. std. HE/sec @ 1 ATM differential
Voltage Drop at 1 amp	0.040 volts max
Insulation	100 megaohms min
Vibration Resistance	65G, 10-2000Hz, .5 DA or 65 G RMS
Shock Resistance	200 G, 6 ms sawtooth

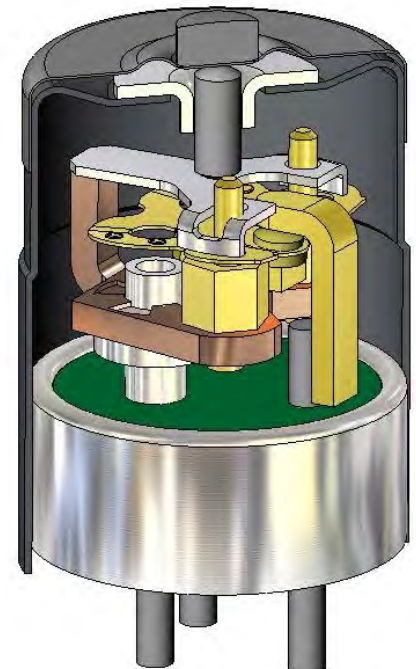

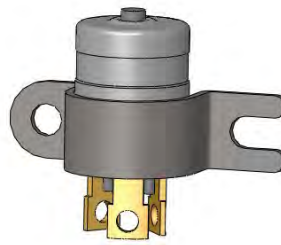

MIL-S-8805 CROSS REFERENCE CHART (SPDT)

Mil Spec	Sensata PN	Plunger Type	Wire Leads	Threaded Mount	Actuating Force	Movement Differential	Pretravel	Overtravel	Release Force
M8805/68-022	10AT117-01	Flat	No Wires	None	30 oz max	0.005" max	0.009" max	0.002" min	4 oz min
M8805/68-023	10AT17-01	Flat	No Wires	7/16-32NS-2A	30 oz max	0.005" max	0.009" max	0.002" min	4 oz min
M8805/68-024	10AT17-02-10	Flat	Parallel	7/16-32NS-2A	30 oz max	0.005" max	0.009" max	0.002" min	4 oz min
M8805/68-025	10AT17-03-10	Flat	90° Angle	7/16-32NS-2A	30 oz max	0.005" max	0.009" max	0.002" min	4 oz min
M8805/68-026	10AT15-01	Flat	No Wires	Bracket Mount	30 oz max	0.005" max	0.009" max	0.002" min	4 oz min
M8805/68-027	10AT15-02-10	Flat	Parallel	Bracket Mount	30 oz max	0.005" max	0.009" max	0.002" min	4 oz min
M8805/68-028	10AT15-03-10	Flat	90° Angle	Bracket Mount	30 oz max	0.005" max	0.009" max	0.002" min	4 oz min

DIMENSIONAL DRAWINGS – Threaded Mount (10AT17-01), Basic Switch (10AT117-01), Bracket Mount (10AT15-01), Flat Plunger

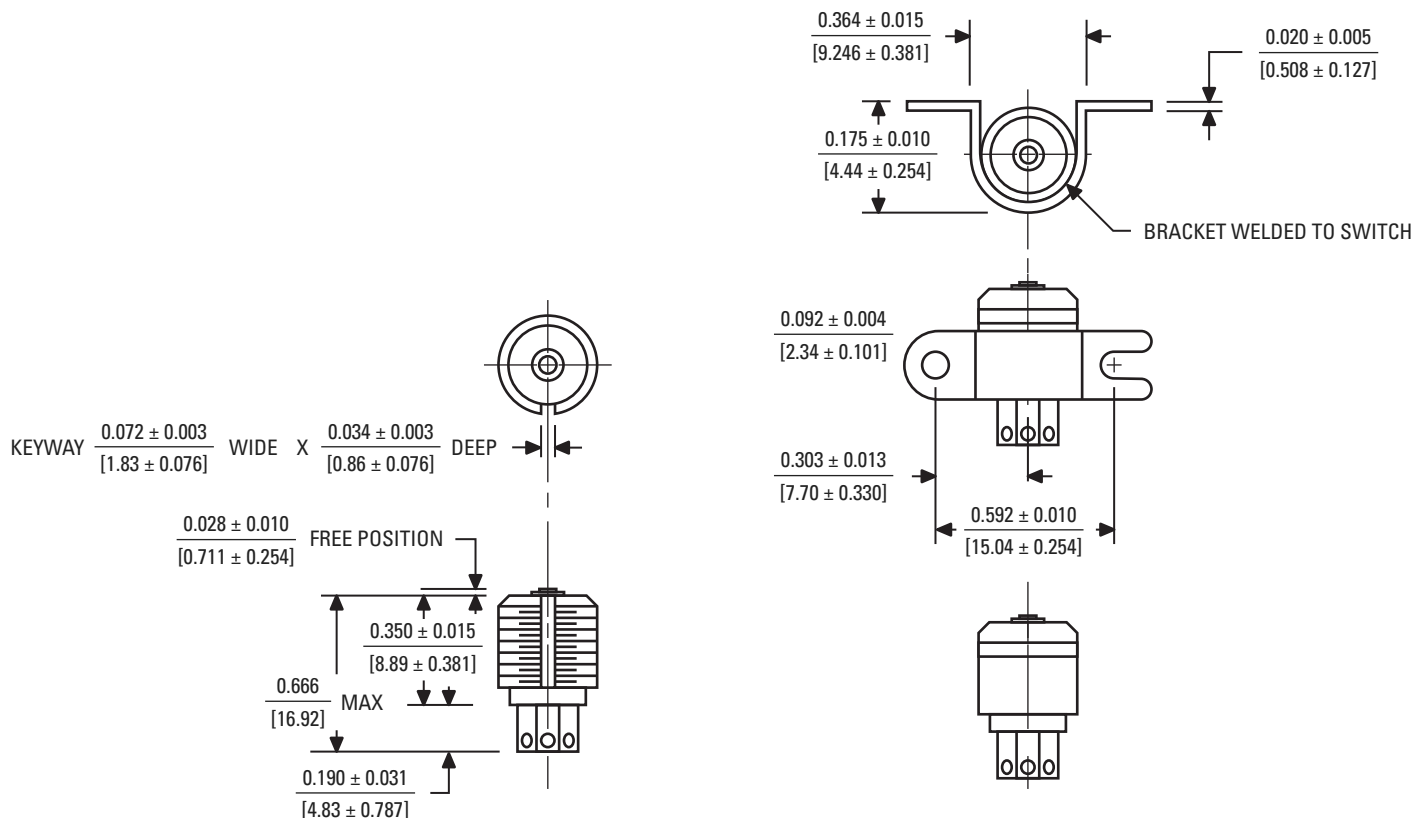



MIL-S-8805 CROSS REFERENCE CHART (SPDT)

Mil Spec	Sensata PN	Plunger Type	Wire Leads	Threaded Mount	Actuating Force	Movement Differential	Pretravel	Overtravel	Release Force
M8805/72-033	10AT363-02-10	Flat	Parallel	5/16-24UNF-2A	30 oz max	0.005" max	0.010" max	0.125" min	4 oz min
M8805/72-034	10AT361-02-10	Flat	Parallel	5/16-24UNF-2A Short	30 oz max	0.005" max	0.010" max	0.125" min	4 oz min
M8805/72-035	10AT363-03-10	Flat	90° Angle	5/16-24UNF-2A	30 oz max	0.005" max	0.010" max	0.125" min	4 oz min
M8805/72-036	10AT361-03-10	Flat	90° Angle	5/16-24UNF-2A Short	30 oz max	0.005" max	0.010" max	0.125" min	4 oz min
M8805/72-037	10AT364-02-10	Spherical	Parallel	5/16-24UNF-2A	30 oz max	0.005" max	0.010" max	0.125" min	4 oz min
M8805/72-038	10AT362-02-10	Spherical	Parallel	5/16-24UNF-2A Short	30 oz max	0.005" max	0.010" max	0.125" min	4 oz min
M8805/72-039	10AT364-03-10	Spherical	90° Angle	5/16-24UNF-2A	30 oz max	0.005" max	0.010" max	0.125" min	4 oz min
M8805/72-040	10AT362-03-10	Spherical	90° Angle	5/16-24UNF-2A Short	30 oz max	0.005" max	0.010" max	0.125" min	4 oz min
M8805/73-013	10AT7-02-10	Flat	Parallel	3/8-32 NEF-2A	104 oz max	0.010" max	0.020" max	0.125" min	24 oz min
M8805/73-014	10AT7-03-10	Flat	90° Angle	3/8-32 NEF-2A	104 oz max	0.010" max	0.020" max	0.125" min	24 oz min
M8805/73-015	10AT76-02-10	Spherical	Parallel	3/8-32 NEF-2A	104 oz max	0.010" max	0.020" max	0.125" min	24 oz min
M8805/73-016	10AT76-03-10	Spherical	90° Angle	3/8-32 NEF-2A	104 oz max	0.010" max	0.020" max	0.125" min	24 oz min

DIMENSIONAL DRAWINGS – Threaded Mount, Flat Plunger, Hex Body Configuration (10AT363-01, 10AT363-02, 10AT363-03)

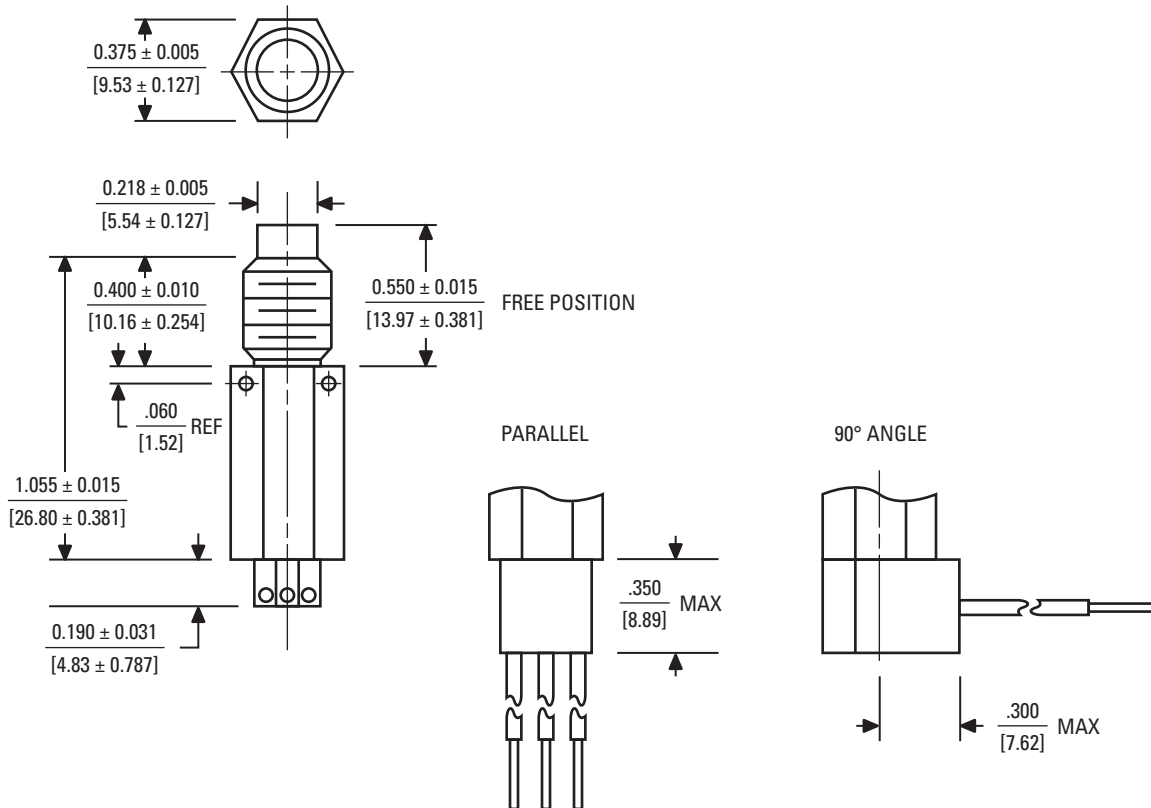



MIL-S-8805 CROSS REFERENCE CHART (SPDT)

Mil Spec	Sensata PN	Plunger Type	Wire Leads	Threaded Mount	Actuating Force	Movement Differential	Pretravel	Overtravel	Release Force
M8805/74-035	10AT366-02-10	Flat	Parallel	15/32-32NS-2A	30 oz max	0.005" max	0.010" max	0.125" min	4 oz min
M8805/74-036	10AT368-02-10	Roller	Parallel	15/32-32NS-2A	30 oz max	0.005" max	0.010" max	0.125" min	4 oz min
M8805/74-037	10AT366-03-10	Flat	90° Angle	15/32-32NS-2A	30 oz max	0.005" max	0.010" max	0.125" min	4 oz min
M8805/74-038	10AT368-03-10	Roller	90° Angle	15/32-32NS-2A	30 oz max	0.005" max	0.010" max	0.125" min	4 oz min
M8805/74-039	10AT369-02-10	Flat, O-Ring	Parallel	15/32-32NS-2A	112 oz max	0.005" max	0.020" max	0.125" min	24 oz min
M8805/74-040	10AT371-02-10	Roller, O-Ring	Parallel	15/32-32NS-2A	112 oz max	0.005" max	0.020" max	0.125" min	24 oz min
M8805/74-041	10AT369-03-10	Flat, O-Ring	90° Angle	15/32-32NS-2A	112 oz max	0.005" max	0.020" max	0.125" min	24 oz min
M8805/74-042	10AT371-03-10	Roller, O-Ring	90° Angle	15/32-32NS-2A	112 oz max	0.005" max	0.020" max	0.125" min	24 oz min
M8805/74-043	10AT367-02-10	Spherical	Parallel	15/32-32NS-2A	30 oz max	0.005" max	0.010" max	0.125" min	4 oz min
M8805/74-044	10AT367-03-10	Spherical	90° Angle	15/32-32NS-2A	30 oz max	0.005" max	0.010" max	0.125" min	4 oz min
M8805/74-045	10AT370-02-10	Spherical, O-Ring	Parallel	15/32-32NS-2A	112 oz max	0.005" max	0.020" max	0.125" min	24 oz min
M8805/74-046	10AT370-03-10	Spherical, O-Ring	90° Angle	15/32-32NS-2A	112 oz max	0.005" max	0.020" max	0.125" min	24 oz min

DIMENSIONAL DRAWINGS – Threaded Mount, Spherical Plunger Configuration (10AT367-01, 10AT367-02, 10AT367-03)

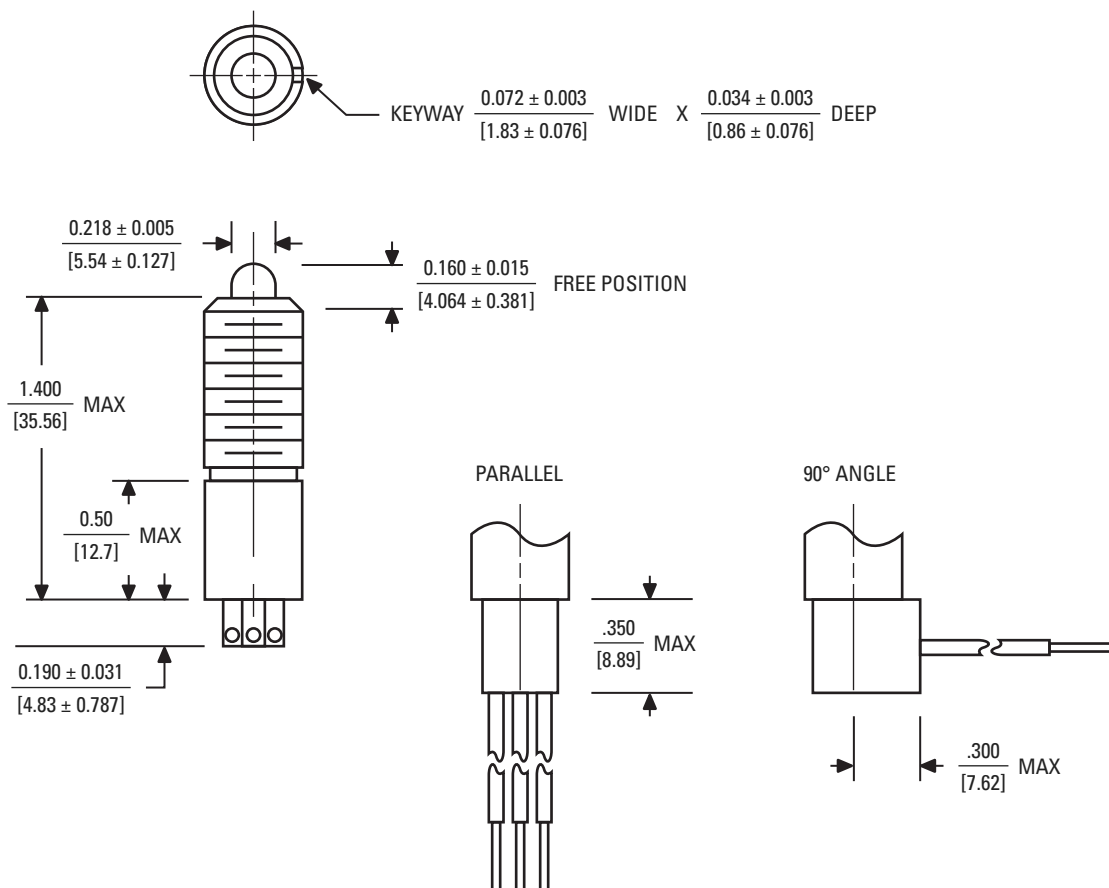



MIL-S-8805 CROSS REFERENCE CHART (2PDT)

Mil Spec	Sensata PN	Plunger Type	Wire Leads	Threaded Mount	Actuating Force	Movement Differential	Pretravel	Overtravel	Release Force
M8805/70-033	10AT372-32-10	Flat	Parallel	15/32-32NS-2A	160 oz max	0.020" max	0.020" to 0.030"	0.200" min	16 oz min
M8805/70-034	10AT373-32-10	Roller	Parallel	15/32-32NS-2A	160 oz max	0.020" max	0.020" to 0.030"	0.200" min	16 oz min
M8805/70-035	10AT372-33-10	Flat	90° Angle	15/32-32NS-2A	160 oz max	0.020" max	0.020" to 0.030"	0.200" min	16 oz min
M8805/70-036	10AT373-33-10	Roller	90° Angle	15/32-32NS-2A	160 oz max	0.020" max	0.020" to 0.030"	0.200" min	16 oz min

DIMENSIONAL DRAWINGS – Threaded Mount, Roller Plunger, 4PDT Configuration (10AT374-102-10 & 10AT374-103-10)

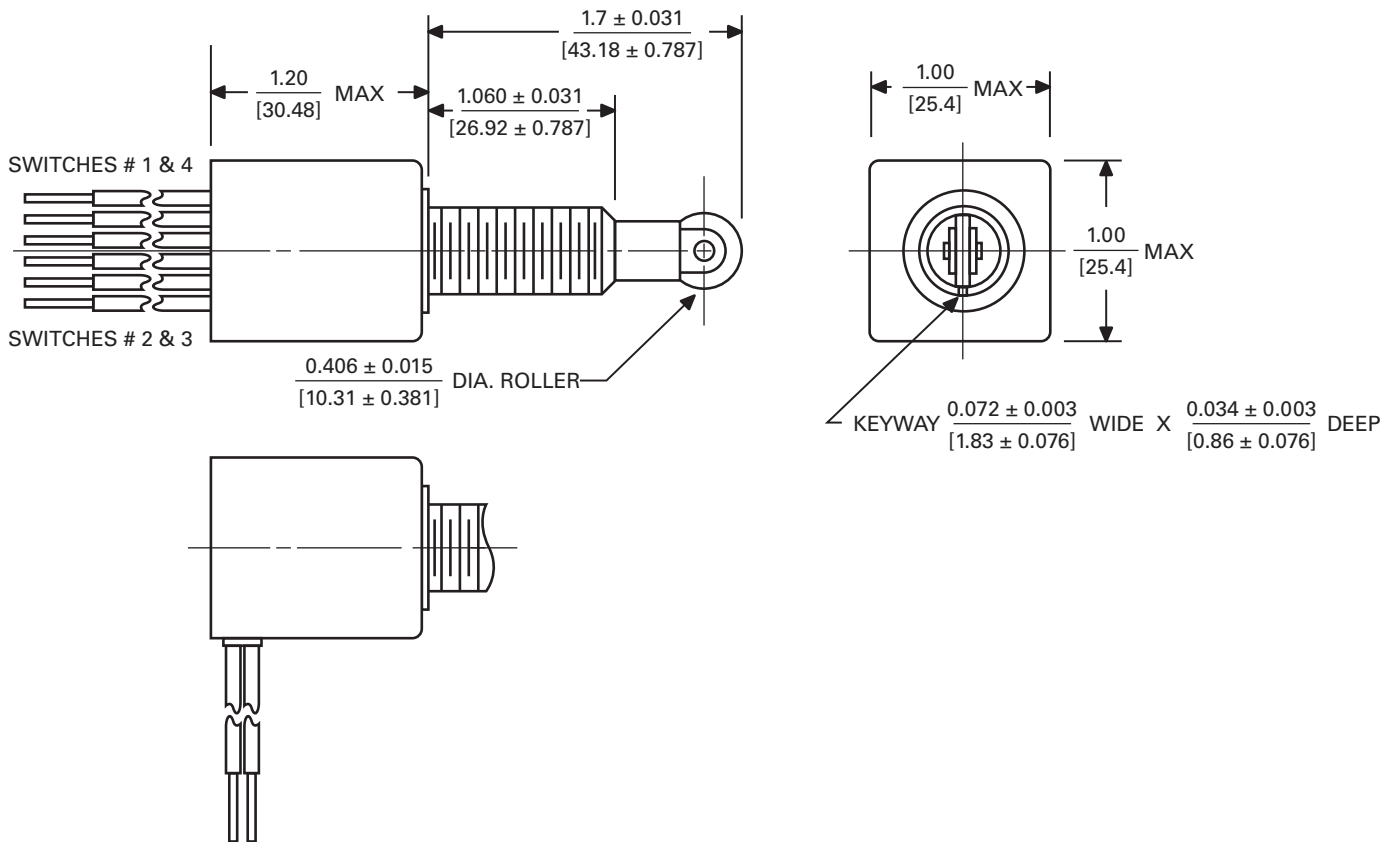

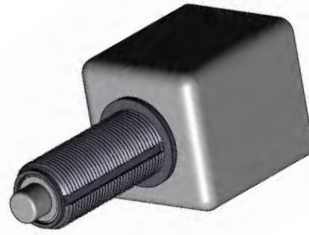

MIL-S-8805 CROSS REFERENCE CHART (4PDT)

Mil Spec	Sensata PN	Plunger Type	Connector	Threaded Mount	Actuating Force	Movement Differential	Pretravel	Overtravel	Release Force
M8805/116-022	10AT493-1	Flat	D38999/25YB35PN Connector	15/32-32NS-2A	160 oz max	0.020" max	0.030" max	0.200" min	16 oz min
M8805/70-037	10AT375-102-10	Flat	Parallel	15/32-32NS-2A	160 oz max	0.020" max	0.030" max	0.200" min	16 oz min
M8805/70-038	10AT374-102-10	Roller	Parallel	15/32-32NS-2A	160 oz max	0.020" max	0.030" max	0.200" min	16 oz min
M8805/70-039	10AT375-103-10	Flat	90° Angle	15/32-32NS-2A	160 oz max	0.020" max	0.030" max	0.200" min	16 oz min
M8805/70-040	10AT374-103-10	Roller	90° Angle	15/32-32NS-2A	160 oz max	0.020" max	0.030" max	0.200" min	16 oz min

DIMENSIONAL DRAWINGS – Threaded Mount, 4PDT, Flat Plunger Configuration (10AT493)

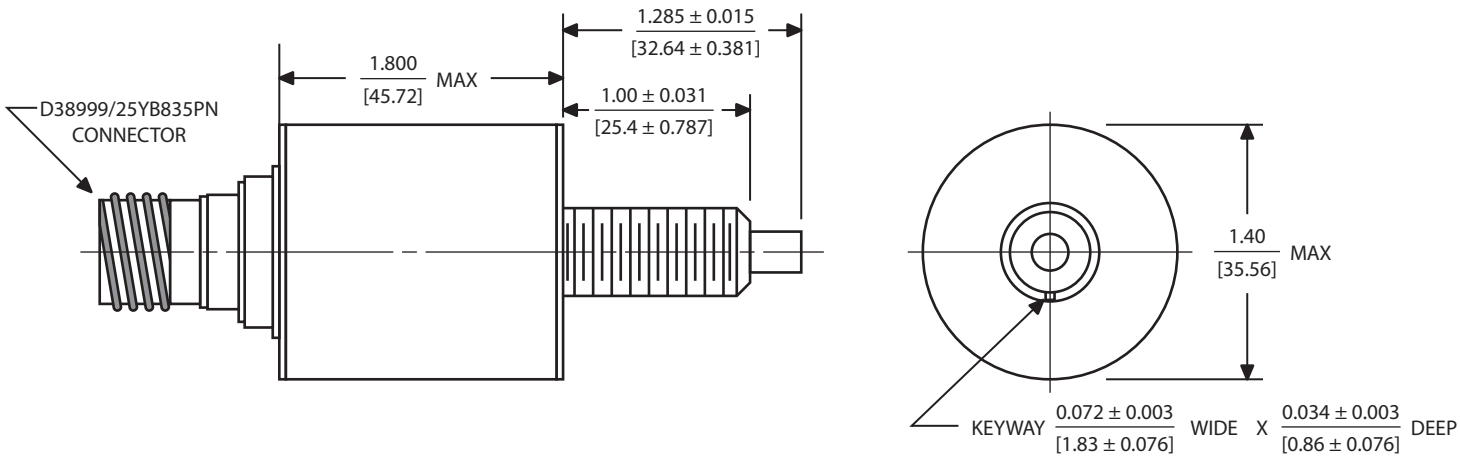

STANDARD PART NUMBER BUILDER

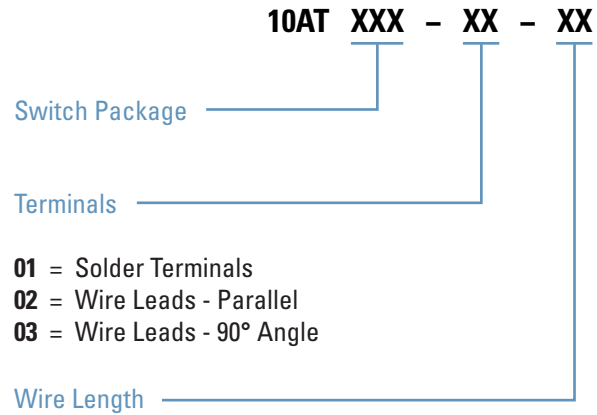

- 01** = Solder Terminals
- 02** = Wire Leads - Parallel
- 03** = Wire Leads - 90° Angle

No dash # needed if solder terminals

- 1** = 6" (152mm)
- 2** = 12" (305mm)
- 3** = 18" (457mm)
- 4** = 24" (610mm)
- 5** = 30" (762mm)
- 6** = 36" (914mm)
- 7** = 42" (1067mm)
- 8** = 48" (1219mm)
- 9** = 60" (1524mm)
- 10** = 72" (1829mm)

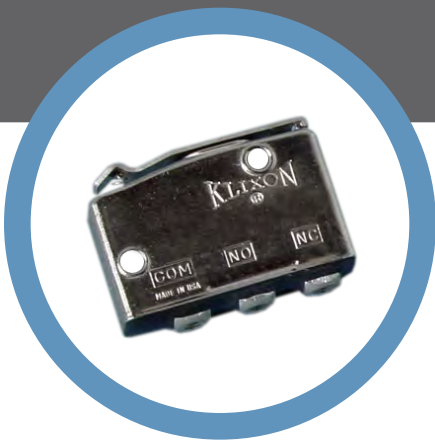

KLIXON | KX Series

Precision Sine Switches

FEATURES

- Hermetic seal provides exceptional operational freedom from environmental conditions
- Compactly designed to fit small, narrow spaces
- Available with either screw or solder lug type terminals
- Snap-acting sine switch provides exceptional resistance to shock and vibration
- Embedded leads are available
- Lead lengths can be supplied to customer requirements

INTRODUCTION

The Klixon® KX Series hermetically sealed sine switch is a precision snap-acting device. It is designed for use in the aerospace industry and for other applications where operational freedom from environmental conditions is a requirement.

KX series switches are sealed within a one-piece steel case engineered to withstand extremely low or high ambient pressures. True hermetic sealing is achieved with a metal “wave type” diaphragm at the actuating lever. The actuating arm is keyed to hold the arm in alignment and to prevent damage to the diaphragm.

The switching element is the versatile Klixon® sine switch. This simple, one-piece element eliminates knife edges and high friction joints. Rigidly supported at both ends and accurately prestressed in tension, the sine switch features outstanding resistance to shock and vibration.

Klixon® switches have been used in a variety of aircraft, weapons systems, aircraft engine and aerospace applications for well over 30 years. A brief listing of typical applications include:

- Door interlock systems
- Aircraft engine ignitions
- Aircraft missile launcher position indication
- External stores emergency jettison switches
- Stowed / deployed indication for thrust reversers
- Safety ignition indication for military jet engines
- Radar pod door switches
- Tank/armored personnel carrier missile launcher switches
- Tank gun turret position indication

KX - 4 - 1 - 1

Seal		Max Ambient Temperature		Terminals	
4	Epoxy Sealed (class 4)	1	KX4 - 160°F (71°C) KX5 - 275°F (135°C)	1	Solder Lug
5	Hermetically Sealed (class 5, MIL-S-8805)	2	KX5 - 375°F (191°C)	2	Screw

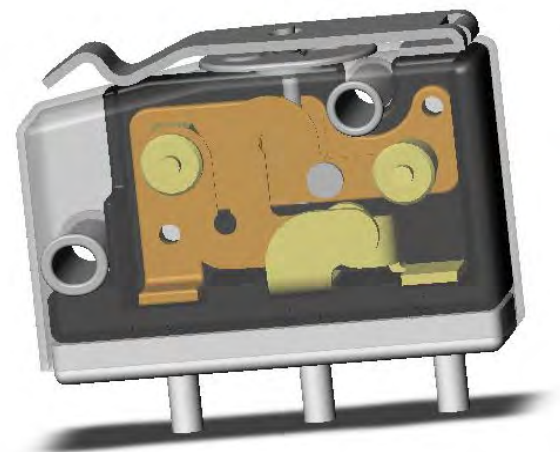

PERFORMANCE & ACTUATION CHARACTERISTICS CHART

		KX4-1-1 KX4-1-2	KX5-1-1 KX5-1-2	KX5-2-1 KX5-2-2
Device Type		Environmental Seal	Hermetic Seal	Hermetic Seal, High Temperature
Actuating Force (STP)		8 to 24 oz	8 to 24 oz	16 to 48 oz
Min Release Force (STP)		3 oz	3 oz	3 oz
Max Pretravel		0.025"	0.025"	0.035"
Max Movement Differential		0.020"	0.020"	0.024"
Min Overtravel		0.015"	0.015"	0.015"
Positive, Overtravel Stop		Yes	Yes	Yes
Max Force on Actuator		25 lb	25 lb	25 lb
Current Ratings in Amps 28VDC & 110VAC 60-400Hz	Resistance	10	10	5
	Inductive	5	5	3
	Lamp	3	3	2
Min Life @ Rated Load		25K	25K	25K
Ambient Temperature Range		-65°F to 160°F (-53.8°C to 71.1°C)	-65°F to 275°F (-53.8°C to 135°C)	-65°F to 375°F (-53.8°C to 190.5°C)
Dielectric Strength		1250 VRMS	1250 VRMS	1250 VRMS
Shock Resistance		100G w/o damage		
Vibration Resistance		20G		
Contact Arrangement		SPDT	SPDT	SPDT
Backfill		—	Dry nitrogen with 10% helium	Dry nitrogen with 10% helium
Seal (MIL-S-8805)		Resilent, Class 4 (epoxy seal)	Fusion, Class 5 (hermetic seal)	Fusion, Class 5 (hermetic seal)
Max Leakage		1 x 10 ⁻⁶ Std. cc He/Sec	1 x 10 ⁻⁸ Std. cc He/Sec	1 x 10 ⁻⁸ Std. cc He/Sec

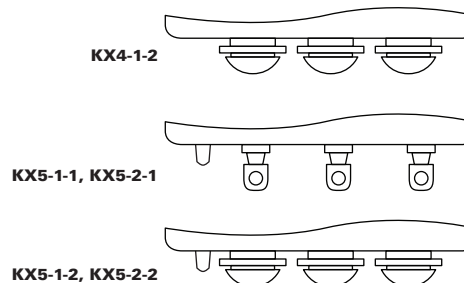
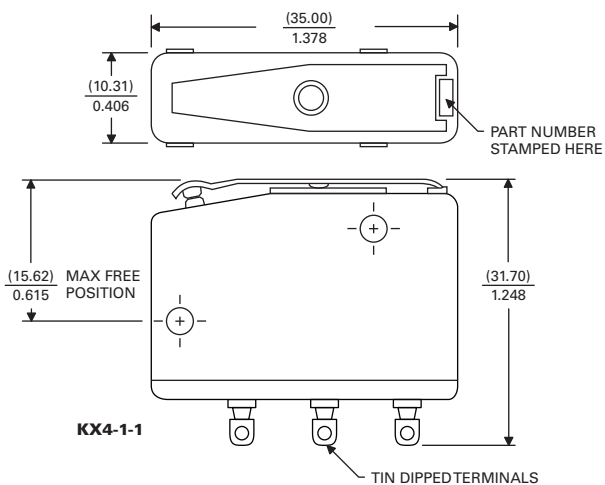

001 SINE SWITCH PACKAGE, 1 POLE (10 amps)

Basic Switch		
KX4	KX5	KX52
sealed	hermetic	hermetic hi temp
Actuating Force (max)	24 oz	24 oz
Release Force (max)	3 oz	3 oz
Pretravel (max)	.025" (1.02mm)	
Movement Diff. (max)	.020" (.76mm)	
Overtravel (min)	.015" (3.18mm)	
Ambient Temperature Range	-67°F to 160°F (-55°C to 71°C)	
Dielectric Strength	1250 VRMS terminal to terminal 1250 VRMS terminal to case	
Approx Weight (no leads)	0.90 oz	

Actuating Force (max)
Release Force (max)
Pretravel (max)
Movement Diff. (max)
Overtravel (min)
Ambient Temperature Range
Dielectric Strength
Approx Weight (no leads)

KX5 - 001 - 0 3 - 10

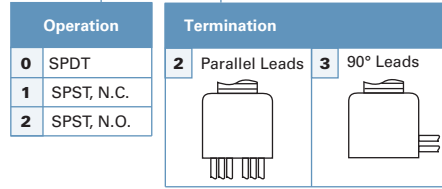

Lead Length	
1	6" (153mm)
2	12" (305mm)
3	18" (458mm)
4	24" (610mm)
5	30" (762mm)
6	36" (915mm)
7	42" (1067mm)
8	48" (1220mm)
9	60" (1524mm)
10	72" (1829mm)

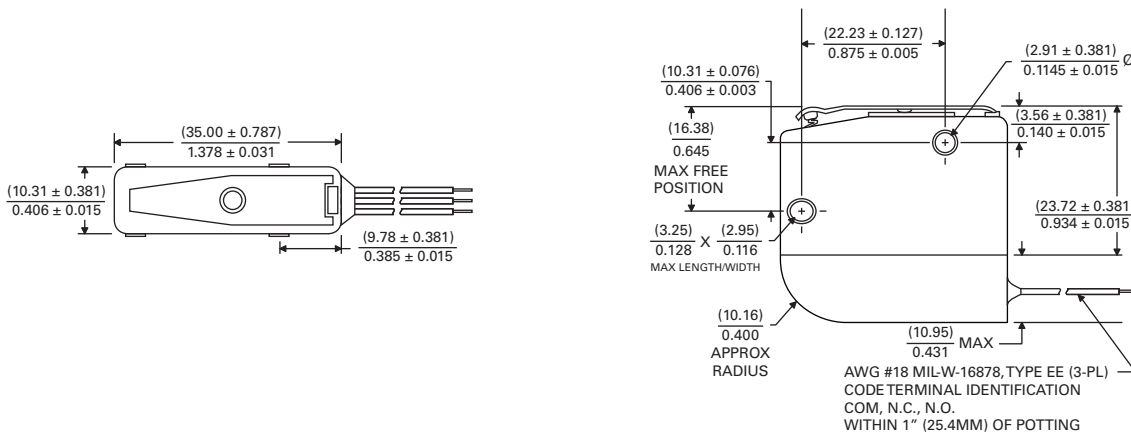

002 SIDE PLATE SWITCH PACKAGE, 1 POLE (10 amps)

Basic Switch		
KX4	KX5	KX52
std	hi amp	hi amp
Actuating Force (max)	48 oz	48 oz
Release Force (max)	8 oz	8 oz
Movement Diff. (max)	.090" (2.29mm)	

Actuating Force (max)
Release Force (max)
Movement Diff. (max)

KX5 - 002 - 0 3 - 6

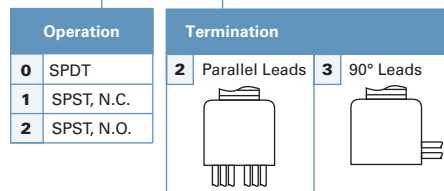

Lead Length	
1	6" (153mm)
2	12" (305mm)
3	18" (458mm)
4	24" (610mm)
5	30" (762mm)
6	36" (915mm)
7	42" (1067mm)
8	48" (1220mm)
9	60" (1524mm)
10	72" (1829mm)

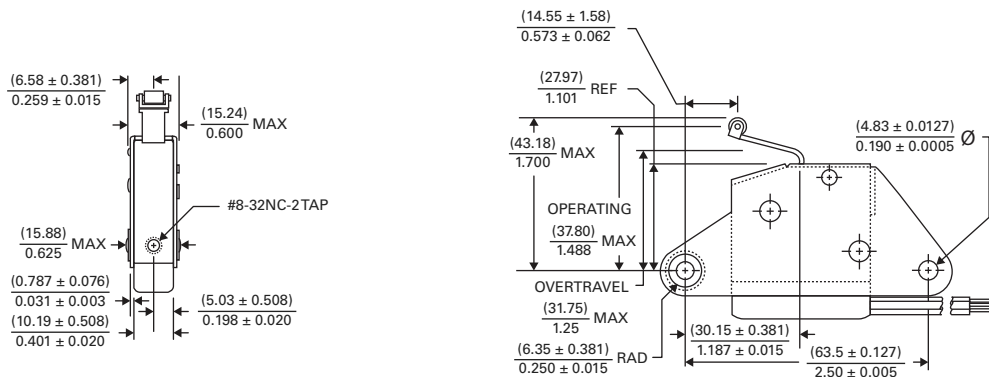

003 SIDE PLATE SWITCH PACKAGE, 2 POLE (10 amps)

Basic Switch		
KX4	KX5	KX52
std	hi amp	hi amp
Actuating Force (max)	96 oz	96 oz
Overtravel Force (max)	160 oz	160 oz
Pretravel (max)	.100" (2.54mm)	
Movement Diff. (max)	.06" (1.53mm)	
Overtravel (min)	.175" (4.45mm)	
Ambient Temperature Range	-65°F to 275°F (-54°C to 135°C)	
Approx Weight (no leads)	12 oz	

Actuating Force (max)
Overtravel Force (max)
Pretravel (max)
Movement Diff. (max)
Overtravel (min)
Ambient Temperature Range
Approx Weight (no leads)

KX5 - 003 - 3 2 - 8

Operation		Termination	
3	DPDT	2	Parallel Leads
4	DPST, N.C.	3	90° Leads
5	DPST, N.O.		
6	DPST, N.C., N.O.		

Lead Length	
1	6" (153mm)
2	12" (305mm)
3	18" (458mm)
4	24" (610mm)
5	30" (762mm)
6	36" (915mm)
7	42" (1067mm)
8	48" (1220mm)
9	60" (1524mm)
10	72" (1829mm)

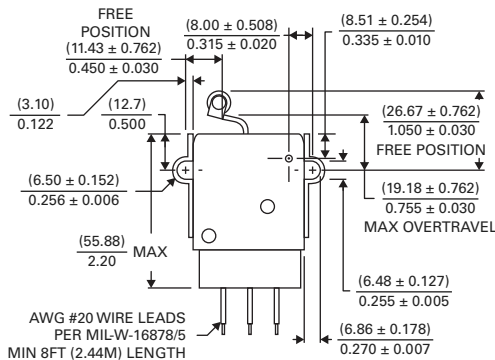
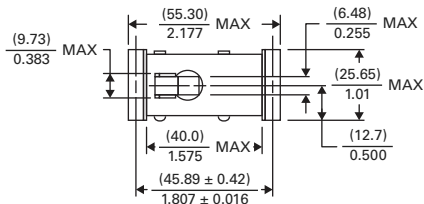

004 ROLLER LEAF SWITCH PACKAGE, 2 POLE (10 amps)

Basic Switch		
KX4	KX5	KX52
sealed	hermetic	hermetic hi temp
Actuating Force (max)	160 oz	160 oz
Release Force (max)	32 oz	32 oz
Pretravel (max)	.150" (3.81mm)	
Movement Diff. (max)	.020" (.76mm)	
Overtravel (min)	.450" (11.43mm)	

Actuating Force (max)
Release Force (max)
Pretravel (max)
Movement Diff. (max)
Overtravel (min)

KX5 - 004 - 3 2 - 10

Operation		Termination	
3	DPDT	2	Parallel Leads
4	DPST, N.C.	3	90° Leads
5	DPST, N.O.		
6	DPST, N.C., N.O.		

Lead Length	
1	6" (153mm)
2	12" (305mm)
3	18" (458mm)
4	24" (610mm)
5	30" (762mm)
6	36" (915mm)
7	42" (1067mm)
8	48" (1220mm)
9	60" (1524mm)
10	72" (1829mm)

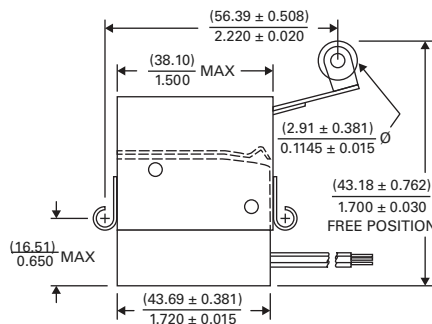
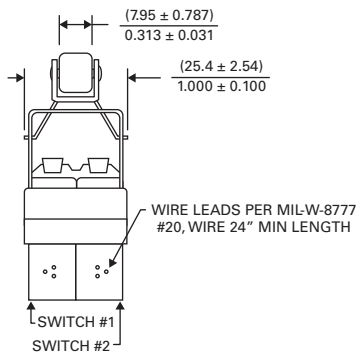

005 PLUNGER SWITCH PACKAGE, 2 POLE (10 amps)

Basic Switch		
KX4	KX5	KX52
std	hi amp	hi amp
Actuating Force (max)	96 oz	96 oz
Release Force (max)	32 oz	32 oz
Pretravel (max)	.075" (1.91mm)	
Movement Diff. (max)	.030" (.76mm)	
Overtravel (min)	.175" (4.45mm)	
Ambient Temperature Range	-65°F to 275°F (-54°C to 135°C)	
Positive Overtravel Stop	Yes	
Max Force on Actuator	20 lbs	
Approx Weight (no leads)	12 oz	

Actuating Force (max)
Release Force (max)
Pretravel (max)
Movement Diff. (max)
Overtravel (min)
Ambient Temperature Range
Positive Overtravel Stop
Max Force on Actuator
Approx Weight (no leads)

KX5 - 005 - 3 3 - 10

Operation	Termination
3 DPDT	2 Parallel Leads
4 DPST, N.C.	3 90° Leads
5 DPST, N.O.	
6 DPST, N.C., N.O.	

Lead Length	
1	6" (153mm)
2	12" (305mm)
3	18" (458mm)
4	24" (610mm)
5	30" (762mm)
6	36" (915mm)
7	42" (1067mm)
8	48" (1220mm)
9	60" (1524mm)
10	72" (1829mm)

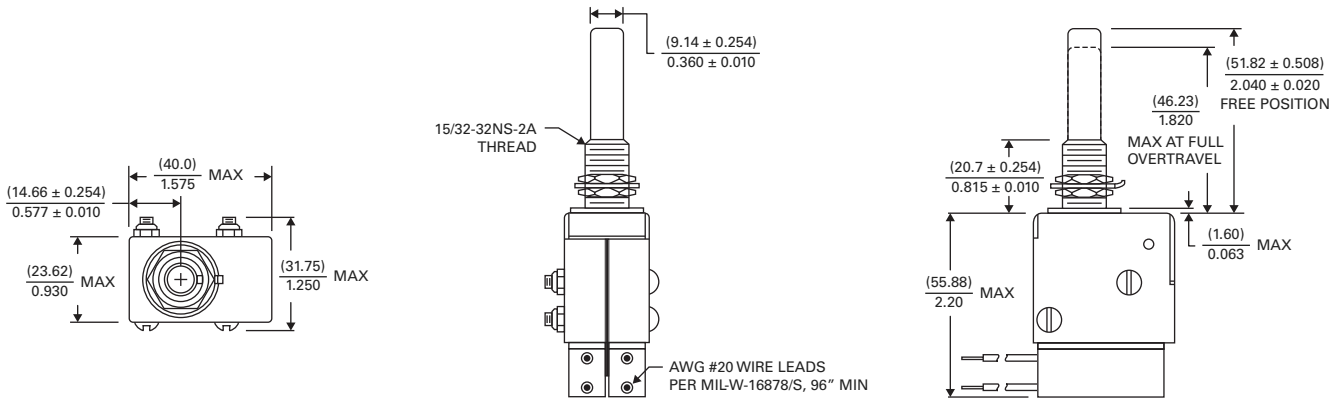

006 LEAF SWITCH PACKAGE, 4 POLE (10 amps)

Basic Switch		
KX4	KX5	KX52
std	hi amp	hi amp
Actuating Force (max)	48 oz	48 oz
Release Force (max)	8 oz	8 oz
Movement Diff. (max)	.090" (2.29mm)	

Actuating Force (max)
Release Force (max)
Movement Diff. (max)

KX5 - 006 - 10 3 - 10

Operation	Termination
7 3PDT	2 Parallel Leads
8 3PST, N.C.	3 90° Leads
9 3PST, N.O.	
10 4PDT	
11 4PST, N.C.	
12 4PST, N.O.	

Lead Length	
1	6" (153mm)
2	12" (305mm)
3	18" (458mm)
4	24" (610mm)
5	30" (762mm)
6	36" (915mm)
7	42" (1067mm)
8	48" (1220mm)
9	60" (1524mm)
10	72" (1829mm)

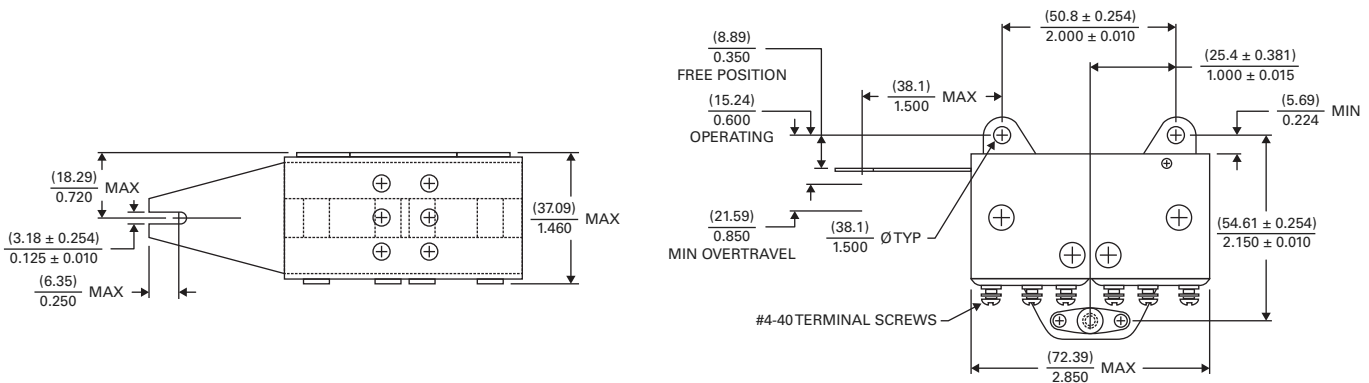

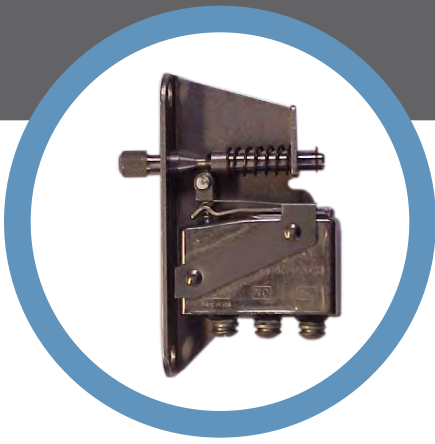

KLIXON® | 4HVS Series

High Performance Hermetic Interlock Switches

FEATURES

- Explosion-proof device
- Stainless steel, hermetic seal construction
- Rated to 10 amps
- Rated for 28 VDC and 110 VAC, 60-900 Hz
- Available in single pole, double throw (SPDT) and double pole, double throw (DPDT)
- Screw or soldier terminals

INTRODUCTION

The Klixon® 4HVS series of interlock switches utilizes a hermetically sealed snap-acting sine switch to create a high reliability yet cost effective solution. The 4HVS Series was developed for the most severe environments, and the most demanding applications. Ideal for guarding engine compartments, access and maintenance hatches, electrical cabinets, machinery, and industrial equipment. Its explosion-proof design and one-piece steel case construction make it well suited for fuel wetted areas. Its high vibration resistance makes it an ideal choice for ground and air vehicle applications.

Our part number building block approach utilizes standard components and provides a wide variety of options...while retaining the cost advantage of off-the-shelf devices.

SPECIFICATIONS		
Current Capacity	28 VDC	115 VAC, 60 - 900Hz
Resistance	10 amps	10 amps
Inductive	5 amps, L/R .026	5 amps PF 0.7
Lamp	3 amps	3 amps
Dielectric Strength	1250 volts (RMS)	
Full Overtavel Force	5 lbs max	
Life @ Rated Load	25,000 cycles	
Amb. Temperature Range	-65F to +275F (-65C to +150C)	
Seal	Hermetic per MIL-S-8805D	
Max Leak Rate	1x10 ⁻⁸ C.C. std. HE/sec	
Backfill	Dry nitrogen	
Max MV Drop	20 MV @ 1 amp	
Vibration Resistance	Swept sinusoidal vibration per MIL-S-8805 Test Condition A	
Shock Resistance	100 G's, 1/2 sine, 11 ms duration	

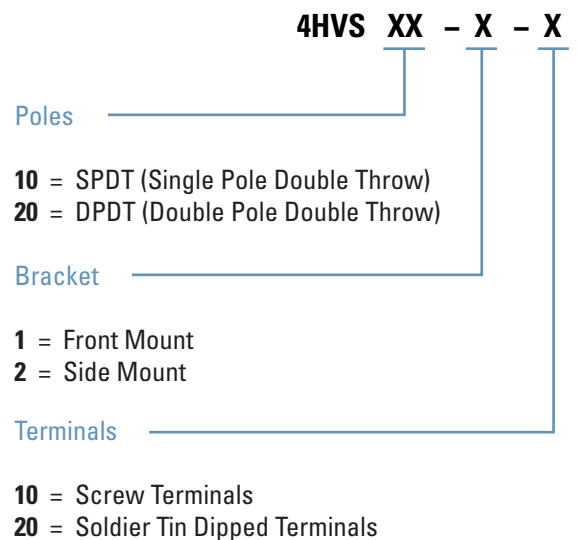

DIMENSIONAL DRAWINGS – 4HVS10-1-10

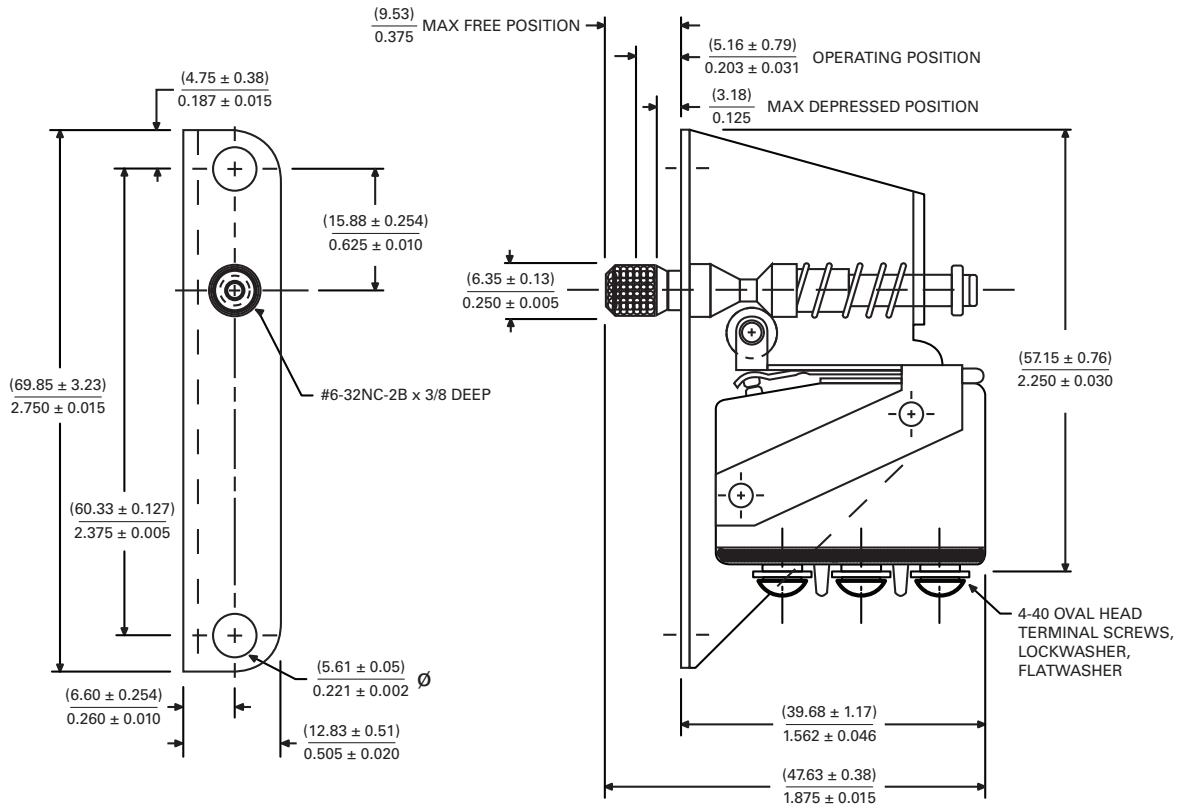

DIMENSIONAL DRAWINGS – 4HVS20-1-10

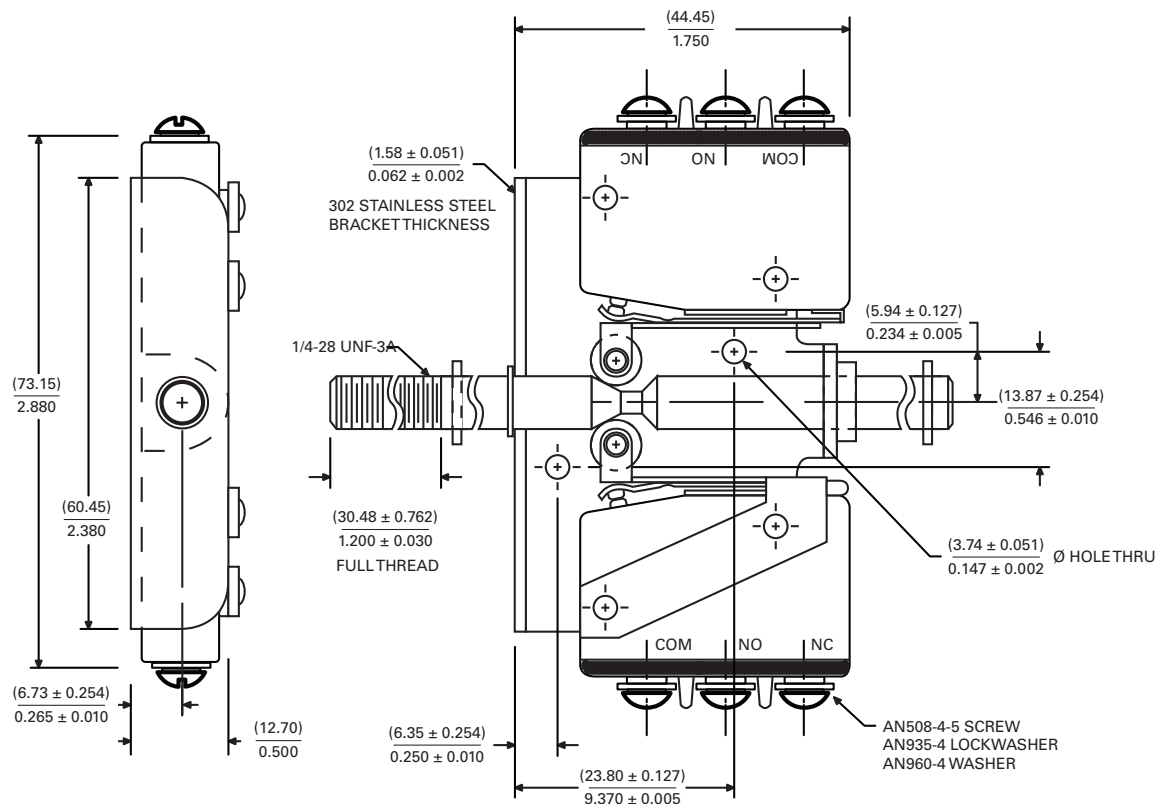

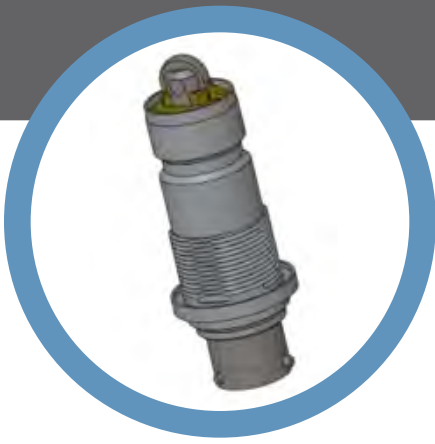

KLIXON | ESS Series

Environmentally Sealed Position Switches

FEATURES

- Meet M8805 level 4 performance requirements
- Single and multi-pole high performance switch packages available
- Various plunger and roller type switches available as standard or custom solutions
- Switching available with AC or DC ratings from .01 amps to 10 amps
- Custom solutions offered with short lead-times

INTRODUCTION

The Klixon® ESS Series of precision limit switches are environmentally sealed to M8805 level 4, and are our most economical precision limit switch solutions. Most package designs include a glass to metal seal and use military qualified basic switches. With this ESS series we continue the practice of offering a wide range of standard package solutions and can quickly offer a customized solution for your specific application needs.

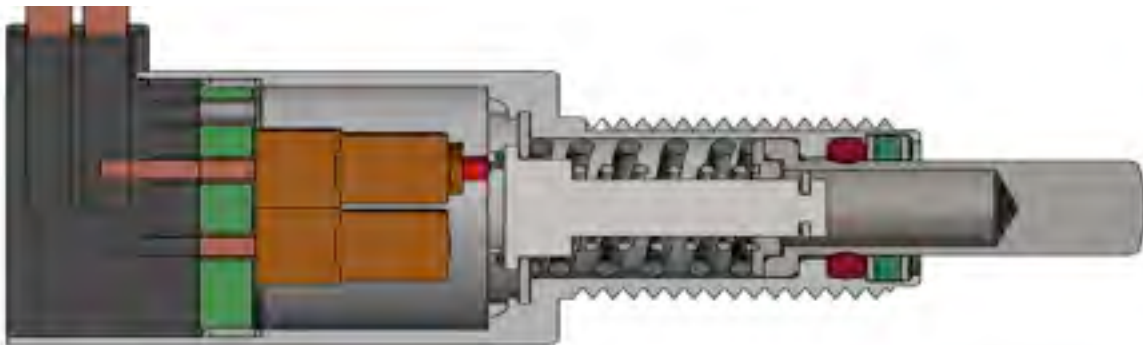

DIMENSIONAL DRAWINGS

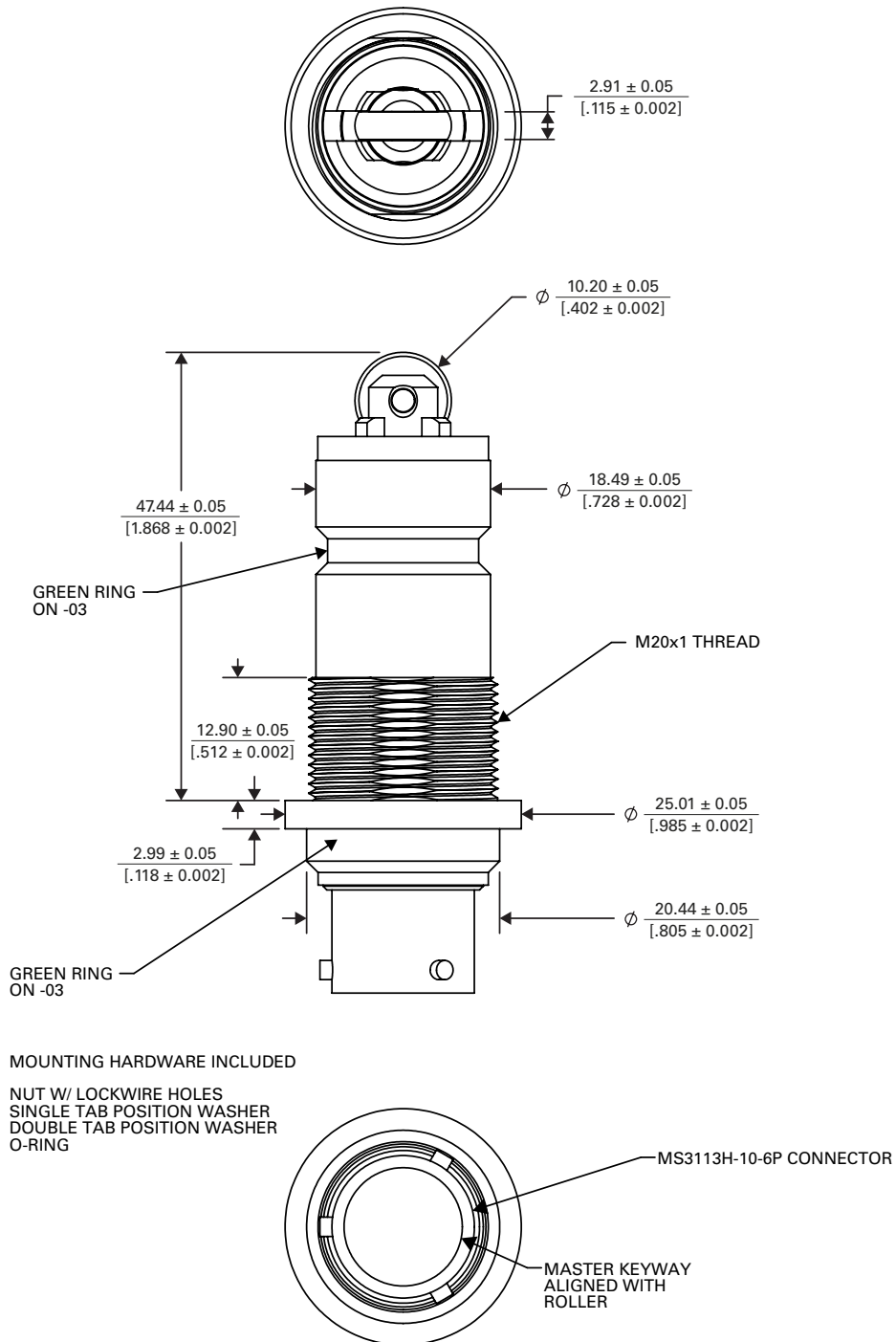



KLIXON® | 6PS & 7PS Series

Hermetic Stainless Steel Pressure Switch

FEATURES

- Hermetically sealed per MIL-E-5400 paragraph 6.3.10
- Covers actuation range of 45 to 700 PSIA
- Maximum corrosion resistance under hostile conditions
 - 300 series stainless steel construction for all environment exposed parts
 - Stainless steel and brass construction for media exposed parts
- High vibration resistance
- 8000 psi minimum burst pressure
- SPDT switch configuration
- Available in a wide range of standard and custom configurations

INTRODUCTION

The Klixon® 6PS and 7PS series precision pressure switches are snap-acting, all-welded devices with hermetically sealed switch contacts. Our pressure switches were developed for applications in aerospace and electronics where high reliability and/or resistance to severe environments is required. To ensure maximum corrosion resistance under hostile conditions, all parts exposed to the pressure media and the environment are made of brass or 300 series stainless steel — no rubber parts are used.

Small and lightweight, 6PS and 7PS Series switches can be mounted by their pressure ports alone, allowing maximum flexibility of design. Full contact force is maintained even during high shock and vibration—regardless of applied pressure—because the positive, snap-action disc works in tandem with snap-action switch contacts.

There are over 1,000 existing 6PS switch package designs. The 6PS is ideal for highly customized package and performance needs. The 7PS is ideal for higher volume standard solution needs.

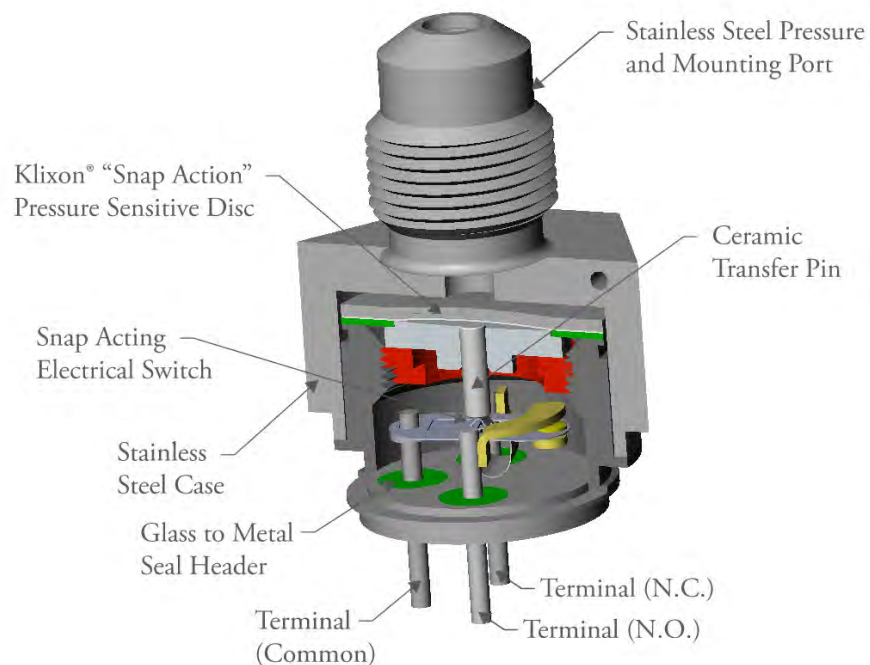

SPECIFICATIONS	
Temperature Rating	-65°F to 275°F (-53.8°C to +135°C)
Vibration Resistance	25 G, 20–2000 cps (no contact chatter in excess of 10 microseconds)
Burst Pressure	8,000 PSI minimum
Proof Pressure	8 times actuating pressure
Life @ Rated Current	50,000 cycles
Current Capacity	Resistive : 5amp @ 28 VDC Inductive : 2amp @ 28 VDC Lamp : 1amp @ 28 VDC
Dielectric Strength	Terminal to terminal : 1000 vrms Terminal to case : 1000 vrms
Weight	Without Leads : 30 grams maximum With Connector : 60 grams maximum
Metal Parts Exposed to Pressure & Environment	300 series stainless steel CA-360-2 (1/2 hard leaded brass)
Potting Material	Epoxy resin

PRESSURE SPECIFICATIONS	
Range of Actuation Pressure Settings	at STP from 45 PSIA to 700 PSIA
Range of Deactuation Pressure Settings	Standard : 60% to 85% of actuation pressure Special : 85% to 90% of actuation pressure
Range of Tolerances on Actuation & Deactuation Pressure	Standard : up to $\pm 6\%$ of actuation pressure (± 10 PSI minimum) Special : up to $\pm 4\%$ of actuation pressure (± 5 PSI minimum) <i>Choice of deactuation pressure setting and tolerances affects price</i>

Actuation Pressure (PSIA)			Deactuation Pressure (PSIA)			
Pressure	Standard Tolerance	Special Tolerance	Standard 60% to 85%	Special 85% to 90%	Standard Tolerance	Special Tolerance
45 to 134	± 10	± 5	28 to 112	40 to 117	± 10	± 5
135 to 164	± 10	± 7	83 to 137	117 to 144	± 10	± 7
165 to 249	± 15	± 10	101 to 208	142 to 216	± 15	± 10
250 to 369	± 20	± 15	153 to 310	217 to 324	± 20	± 15
370 to 429	± 25	± 20	225 to 361	319 to 378	± 25	± 20
430 to 489	± 30	± 20	261 to 412	370 to 432	± 30	± 20
490 to 549	± 35	± 25	297 to 463	421 to 486	± 35	± 25
550 to 599	± 40	± 25	333 to 510	472 to 540	± 40	± 25
600 to 700	Consult Factory					

6PS SERIES - DESIGN TYPE

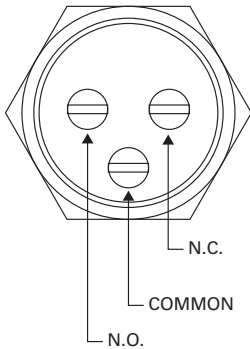

Lockwire holes are $.047 \pm .006$ [$1.19 \pm .15$] diameter. Located $.050 \pm .008$ [$1.27 \pm .20$] from port face of hex

FLATTENED & PIERCED TERMINALS

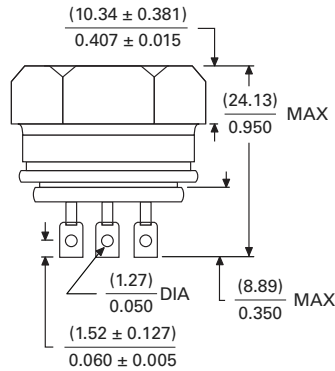

MS33678-10SL-3P (SPDT)
IS33678-10SL-4P (SPST NC/NO)

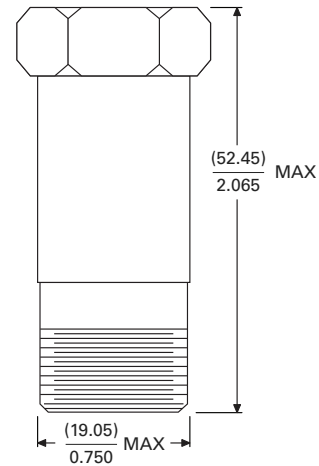

		SPDT	SPDT	SPDT	SPDT	SPST	SPST
1/8" OD Tubing MS 33656 -E2		6PS100 without lock-wire holes	6PS150 with lock-wire holes	6PS102 without lock-wire holes	6PS152 with lock-wire holes	6PS103 without lock-wire holes	6PS153 with lock-wire holes
3/16" OD Tubing MS 33656 -E3		6PS200 without lock-wire holes	6PS250 with lock-wire holes	6PS202 without lock-wire holes	6PS252 with lock-wire holes	6PS203 without lock-wire holes	6PS253 with lock-wire holes
1/4" OD Tubing MS 33656 -E4		6PS300 without lock-wire holes	6PS350 with lock-wire holes	6PS302 without lock-wire holes	6PS352 with lock-wire holes	6PS303 without lock-wire holes	6PS353 with lock-wire holes
5/16" OD Tubing MS 33656 -E5		6PS400 without lock-wire holes	6PS450 with lock-wire holes	6PS402 without lock-wire holes	6PS452 with lock-wire holes	6PS403 without lock-wire holes	6PS453 with lock-wire holes
3/8" OD Tubing MS 33656 -E6		6PS500 without lock-wire holes	6PS550 with lock-wire holes	6PS502 without lock-wire holes	6PS552 with lock-wire holes	6PS503 without lock-wire holes	6PS553 with lock-wire holes
1/8" Pipe Fitting MS 33677		6PS600 without lock-wire holes	6PS650 with lock-wire holes	6PS602 without lock-wire holes	6PS652 with lock-wire holes	6PS603 without lock-wire holes	6PS653 with lock-wire holes
1/4" Pipe Fitting MS 33677		6PS700 without lock-wire holes	6PS750 with lock-wire holes	6PS702 without lock-wire holes	6PS752 with lock-wire holes	6PS703 without lock-wire holes	6PS753 with lock-wire holes

6PS SERIES - DESIGN TYPE

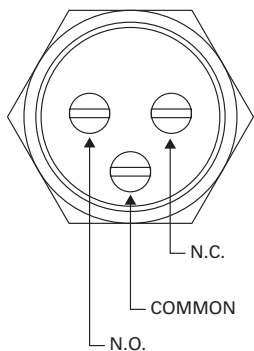

Lockwire holes are $.047 \pm .006$ [$1.19 \pm .15$] diameter. Located $.050 \pm .008$ [$1.27 \pm .20$] from port face of hex

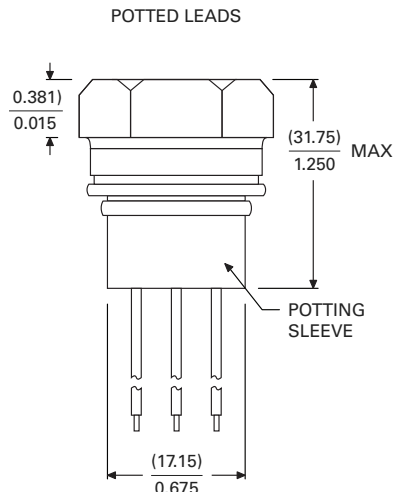
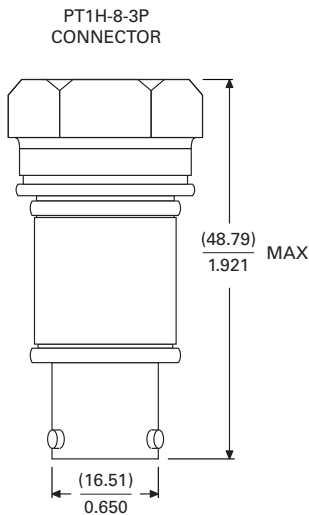

		SPST	SPST	SPDT	SPDT	SPST (NC)	SPST (NC)	SPST (NO)	SPST (NO)
<p>1/8" OD Tubing MS 33656 -E2</p>  <p>3/16" OD Tubing MS 33656 -E3</p>  <p>1/4" OD Tubing MS 33656 -E4</p>  <p>5/16" OD Tubing MS 33656 -E5</p>  <p>3/8" OD Tubing MS 33656 -E6</p>  <p>1/8" Pipe Fitting MS 33677</p>  <p>1/4" Pipe Fitting MS 33677</p> 	<p>6PS104 without lock-wire holes</p>	<p>6PS154 with lock-wire holes</p>	<p>6PS101 without lock-wire holes</p>	<p>6PS151 with lock-wire holes</p>	<p>6PS105 without lock-wire holes</p>	<p>6PS155 with lock-wire holes</p>	<p>6PS106 without lock-wire holes</p>	<p>6PS156 with lock-wire holes</p>	
	<p>6PS204 without lock-wire holes</p>	<p>6PS254 with lock-wire holes</p>	<p>6PS201 without lock-wire holes</p>	<p>6PS251 with lock-wire holes</p>	<p>6PS205 without lock-wire holes</p>	<p>6PS255 with lock-wire holes</p>	<p>6PS206 without lock-wire holes</p>	<p>6PS256 with lock-wire holes</p>	
	<p>6PS304 without lock-wire holes</p>	<p>6PS354 with lock-wire holes</p>	<p>6PS301 without lock-wire holes</p>	<p>6PS351 with lock-wire holes</p>	<p>6PS305 without lock-wire holes</p>	<p>6PS355 with lock-wire holes</p>	<p>6PS306 without lock-wire holes</p>	<p>6PS356 with lock-wire holes</p>	
	<p>6PS404 without lock-wire holes</p>	<p>6PS454 with lock-wire holes</p>	<p>6PS401 without lock-wire holes</p>	<p>6PS451 with lock-wire holes</p>	<p>6PS405 without lock-wire holes</p>	<p>6PS455 with lock-wire holes</p>	<p>6PS406 without lock-wire holes</p>	<p>6PS456 with lock-wire holes</p>	
	<p>6PS504 without lock-wire holes</p>	<p>6PS554 with lock-wire holes</p>	<p>6PS501 without lock-wire holes</p>	<p>6PS551 with lock-wire holes</p>	<p>6PS505 without lock-wire holes</p>	<p>6PS555 with lock-wire holes</p>	<p>6PS506 without lock-wire holes</p>	<p>6PS556 with lock-wire holes</p>	
	<p>6PS604 without lock-wire holes</p>	<p>6PS654 with lock-wire holes</p>	<p>6PS601 without lock-wire holes</p>	<p>6PS651 with lock-wire holes</p>	<p>6PS605 without lock-wire holes</p>	<p>6PS655 with lock-wire holes</p>	<p>6PS606 without lock-wire holes</p>	<p>6PS656 with lock-wire holes</p>	
	<p>6PS704 without lock-wire holes</p>	<p>6PS754 with lock-wire holes</p>	<p>6PS701 without lock-wire holes</p>	<p>6PS751 with lock-wire holes</p>	<p>6PS705 without lock-wire holes</p>	<p>6PS755 with lock-wire holes</p>	<p>6PS706 without lock-wire holes</p>	<p>6PS756 with lock-wire holes</p>	

6PS PART NUMBER BUILDER

See pressure table for standard tolerances for the actuation and deactuation pressures. Note, after building the part number, consult the factory for pricing and to confirm pressure specifications are valid.

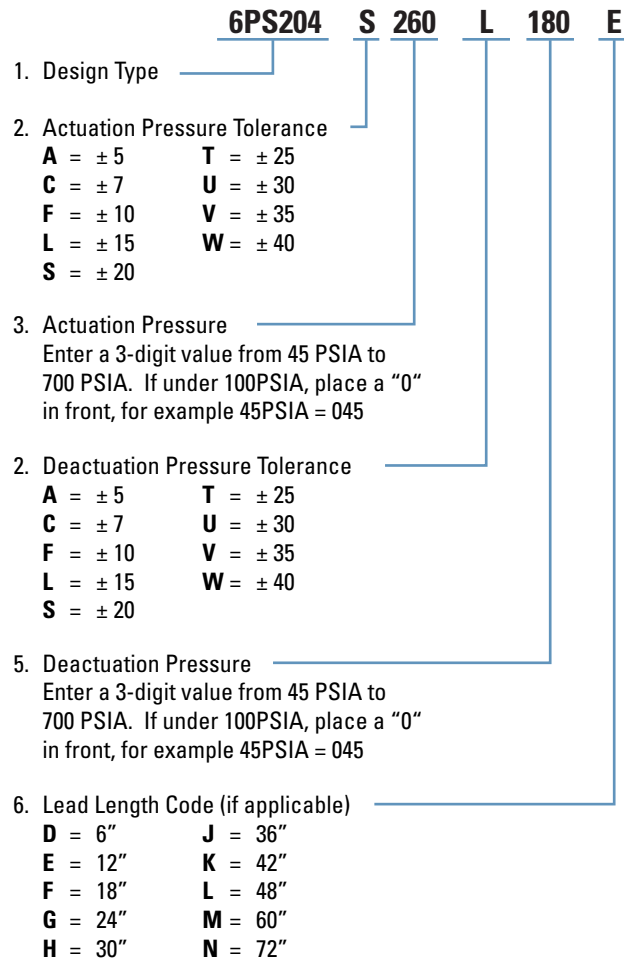

7PS SERIES - DESIGN TYPE

<p>Pressure Port</p> <p>Terminals</p>		<p>FLATTENED & PIERCED TERMINALS</p>	<p>POTTED LEADS</p>	<p>PT1H-8-3P CONNECTOR</p>
		<p>7PS100</p>	<p>7PS101</p>	<p>7PS102</p>
<p>1/8" OD Tubing MS 33656 -E2 (1" HEX)</p>	<p>7PS100</p>	<p>7PS101</p>	<p>7PS102</p>	
<p>3/16" OD Tubing MS 33656 -E3 (1" HEX)</p>	<p>7PS200</p>	<p>7PS201</p>	<p>7PS202</p>	
<p>1/4" OD Tubing MS 33656 -E4 (1" HEX)</p>	<p>7PS300</p>	<p>7PS301</p>	<p>7PS302</p>	
<p>5/16" OD Tubing MS 33656 -E5 (1" HEX)</p>	<p>7PS400</p>	<p>7PS401</p>	<p>7PS402</p>	
<p>3/8" OD Tubing MS 33656 -E6 (1" HEX)</p>	<p>7PS500</p>	<p>7PS501</p>	<p>7PS502</p>	
<p>1/8" Pipe Fitting MS 33677 (1" HEX)</p>	<p>7PS600</p>	<p>7PS601</p>	<p>7PS602</p>	
<p>1/4" Pipe Fitting MS 33677 (1" HEX)</p>	<p>7PS700</p>	<p>7PS701</p>	<p>7PS702</p>	
<p>1" O.D. x 0.040" Flange Mount</p>	<p>7PS800</p>	<p>7PS801</p>	<p>7PS802</p>	

7PS PART NUMBER BUILDER

See pressure table for standard tolerances for the actuation and deactuation pressures. Note, after building the part number, consult the factory for pricing and to confirm pressure specifications are valid.

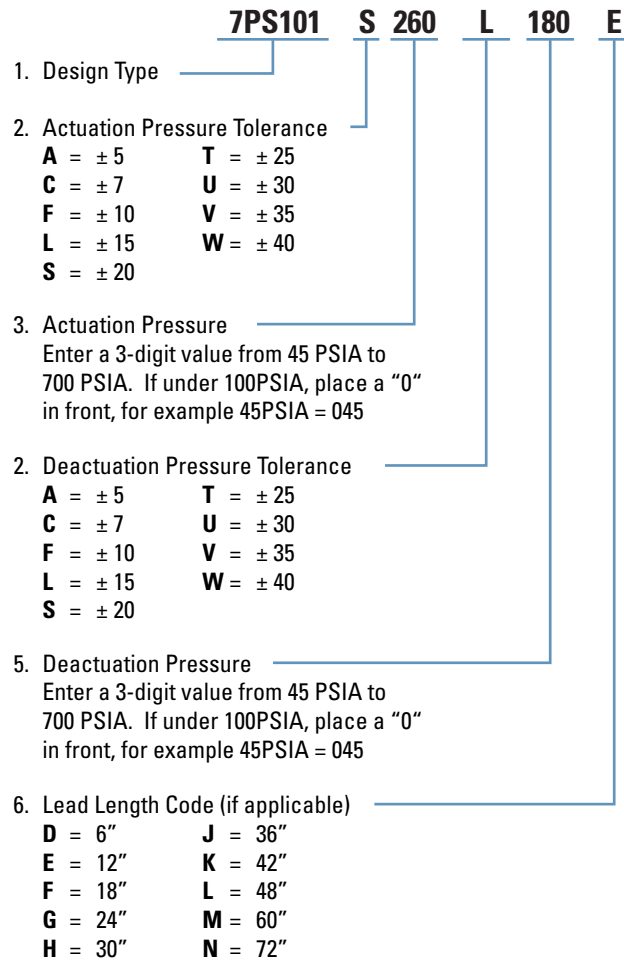



KLIXON® | 2SE Series

Solid-State Air Flow Sensors

FEATURES

- Solid-state design for improved reliability
- SPST or SPDT configuration
- Normally open or normally closed
- Commercial or military grades available
- Low power dissipation (approximately 3 watts)
- Excellent shock and vibration resistance

INTRODUCTION

Sensata is a world leader in the design and manufacture of air flow sensors. We build devices that are high-quality, dependable, and reasonably priced. We can customize Klixon® air flow sensors to meet your engineering needs. Our solid-state vane switch is ideal for recognizing loss or reduction of airflow in electronic equipment. Typically used in power supplies, data processing equipment, and large electronic cabinets.

Unlike its electromechanical vane switch predecessor, our solid-state switch continues to provide reliable switching even in the dirtiest of environments. Klixon® air flow sensors are designed to recognize loss or reduction of airflow in:

- Power supplies
- Data processing units
- Commercial electronic equipment
- Military electronic equipment

SPECIFICATIONS	
Supply Voltage	30 VDC max
Switching Capacity	up to 400 milliamps
Operating Temperature	+10°C to +50°C
Amb. Temperature Range	up to 150°C
Life Cycles	100,000
Average Weight	20 grams

STANDARD PART NUMBER BUILDER

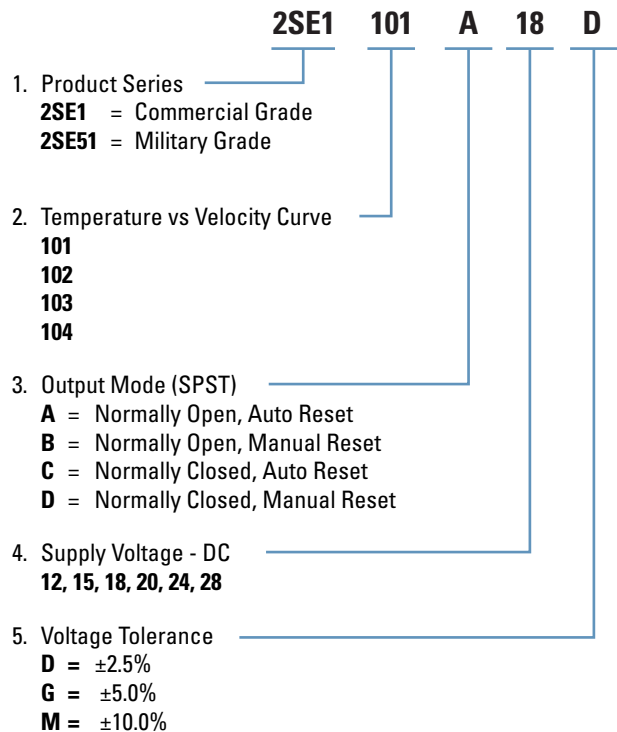

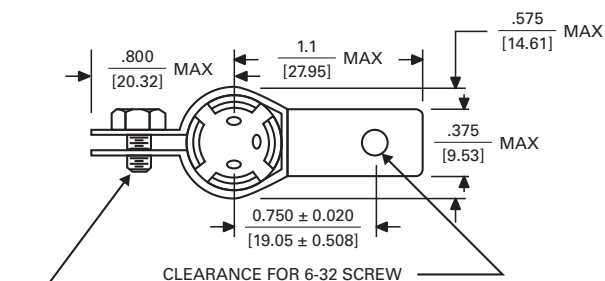
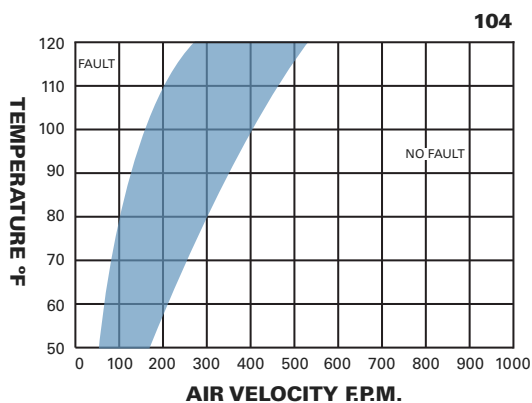
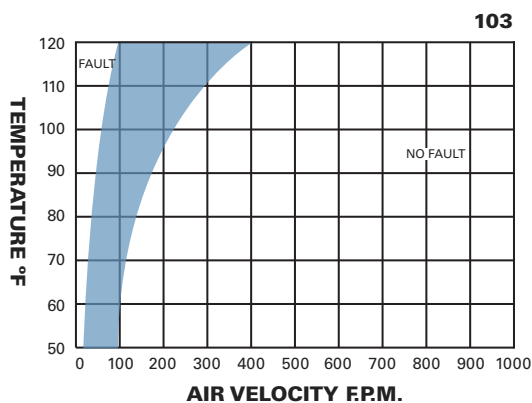
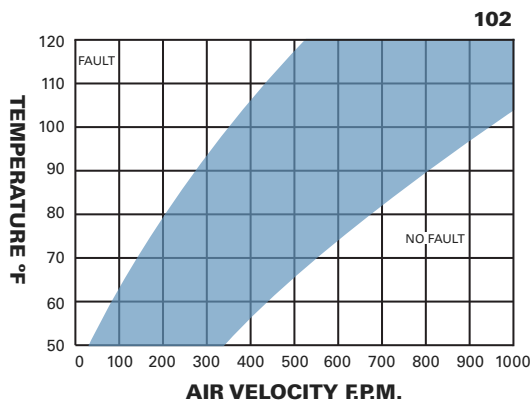
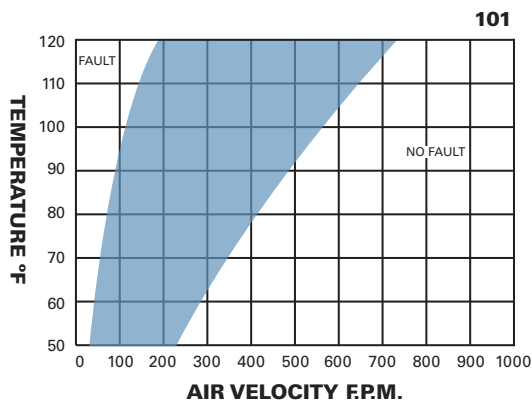

COMMERCIAL GRADE:
SHEET METAL SCREW
MILITARY GRADE:
MACHINE SCREW, WASHER, NUT

TERMINALS ARE GOLD PLATED BRASS

$\frac{0.092 \pm 0.005}{[2.34 \pm 0.127]}$ WIDE X $\frac{0.031 \pm 0.003}{[0.787 \pm 0.08]}$ THICK

WIRE LEADS AVAILABLE INTERNALLY WIRED, 22 AWG

MATING FEMALE QUICK-CONNECT
TERMINALS ARE AVAILABLE, ORDER
P/M 17874-1 FOR KIT OF 3.
(ARK-LES P/N 3700HZC)

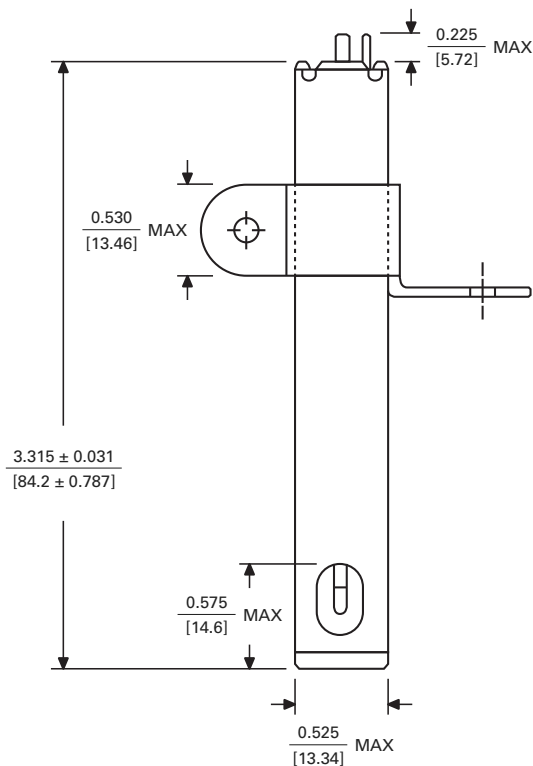

SENSATA M8805 MIL SPEC SWITCH QUALIFICATIONS

Military Specification	Sensata Part Number	Seal	Poles	Configuration	Wire Leads	Threaded Mount
M8805/68-022	10AT117-01	Hermetic	SPDT	Flat Plunger	No Wires	None
M8805/68-023	10AT17-01	Hermetic	SPDT	Flat Plunger	No Wires	7/16-32NS-2A THD
M8805/68-024	10AT17-02-10	Hermetic	SPDT	Flat Plunger	Parallel - 72"	7/16-32NS-2A THD
M8805/68-025	10AT17-03-10	Hermetic	SPDT	Flat Plunger	Right Angle - 72"	7/16-32NS-2A THD
M8805/68-026	10AT15-01	Hermetic	SPDT	Flat Plunger	No Wires	Bracket Mount
M8805/68-027	10AT15-02-10	Hermetic	SPDT	Flat Plunger	Parallel - 72"	Bracket Mount
M8805/68-028	10AT15-03-10	Hermetic	SPDT	Flat Plunger	Right Angle - 72"	Bracket Mount
M8805/70-033	10AT372-32-10	Hermetic	2PDT	Sealed Flat Plunger	Parallel - 72"	15/32-32NS-2A THD
M8805/70-034	10AT373-32-10	Hermetic	2PDT	Sealed Roller Plunger	Parallel - 72"	15/32-32NS-2A THD
M8805/70-035	10AT372-33-10	Hermetic	2PDT	Sealed Flat Plunger	Right Angle - 72"	15/32-32NS-2A THD
M8805/70-036	10AT373-33-10	Hermetic	2PDT	Sealed Roller Plunger	Right Angle - 72"	15/32-32NS-2A THD
M8805/70-037	10AT375-102-10	Hermetic	4PDT	Sealed Flat Plunger	Parallel - 72"	15/32-32NS-2A THD
M8805/70-038	10AT374-102-10	Hermetic	4PDT	Sealed Roller Plunger	Parallel - 72"	15/32-32NS-2A THD
M8805/70-039	10AT375-103-10	Hermetic	4PDT	Sealed Flat Plunger	Right Angle - 72"	15/32-32NS-2A THD
M8805/70-040	10AT374-103-10	Hermetic	4PDT	Sealed Roller Plunger	Right Angle - 72"	15/32-32NS-2A THD
M8805/72-033	10AT363-02-10	Hermetic	SPDT	Flat Plunger	Parallel - 72"	5/16-24UNF-2A THD
M8805/72-034	10AT361-02-10	Hermetic	SPDT	Flat Plunger	Parallel - 72"	5/16-24UNF-2A THD Short
M8805/72-035	10AT363-03-10	Hermetic	SPDT	Flat Plunger	Right Angle - 72"	5/16-24UNF-2A THD
M8805/72-036	10AT361-03-10	Hermetic	SPDT	Flat Plunger	Right Angle - 72"	5/16-24UNF-2A THD Short
M8805/72-037	10AT364-02-10	Hermetic	SPDT	Spherical Plunger	Parallel - 72"	5/16-24UNF-2A THD
M8805/72-038	10AT362-02-10	Hermetic	SPDT	Spherical Plunger	Parallel - 72"	5/16-24UNF-2A THD Short
M8805/72-039	10AT364-03-10	Hermetic	SPDT	Spherical Plunger	Right Angle - 72"	5/16-24UNF-2A THD
M8805/72-040	10AT362-03-10	Hermetic	SPDT	Spherical Plunger	Right Angle - 72"	5/16-24UNF-2A THD Short
M8805/73-013	10AT7-02-10	Hermetic	SPDT	Sealed Flat Plunger	Parallel - 72"	3/8-32 NEF-2A THD
M8805/73-014	10AT7-03-10	Hermetic	SPDT	Sealed Flat Plunger	Right Angle - 72"	3/8-32 NEF-2A THD
M8805/73-015	10AT76-02-10	Hermetic	SPDT	Sealed Spherical Plunger	Parallel - 72"	3/8-32 NEF-2A THD
M8805/73-016	10AT76-03-10	Hermetic	SPDT	Sealed Spherical Plunger	Right Angle - 72"	3/8-32 NEF-2A THD
M8805/74-035	10AT366-02-10	Hermetic	SPDT	Flat Plunger	Parallel - 72"	15/32-32NS-2A THD
M8805/74-036	10AT368-02-10	Hermetic	SPDT	Roller Plunger	Parallel - 72"	15/32-32NS-2A THD
M8805/74-037	10AT366-03-10	Hermetic	SPDT	Flat Plunger	Right Angle - 72"	15/32-32NS-2A THD
M8805/74-038	10AT368-03-10	Hermetic	SPDT	Roller Plunger	Right Angle - 72"	15/32-32NS-2A THD
M8805/74-039	10AT369-02-10	Hermetic	SPDT	Sealed Flat Plunger	Parallel - 72"	15/32-32NS-2A THD
M8805/74-040	10AT371-02-10	Hermetic	SPDT	Sealed Roller Plunger	Parallel - 72"	15/32-32NS-2A THD
M8805/74-041	10AT369-03-10	Hermetic	SPDT	Sealed Flat Plunger	Right Angle - 72"	15/32-32NS-2A THD
M8805/74-042	10AT371-03-10	Hermetic	SPDT	Sealed Roller Plunger	Right Angle - 72"	15/32-32NS-2A THD
M8805/74-043	10AT367-02-10	Hermetic	SPDT	Spherical Plunger	Parallel - 72"	15/32-32NS-2A THD
M8805/74-044	10AT367-03-10	Hermetic	SPDT	Spherical Plunger	Right Angle - 72"	15/32-32NS-2A THD
M8805/74-045	10AT370-02-10	Hermetic	SPDT	Sealed Spherical Plunger	Parallel - 72"	15/32-32NS-2A THD
M8805/74-046	10AT370-03-10	Hermetic	SPDT	Sealed Spherical Plunger	Right Angle - 72"	15/32-32NS-2A THD

"CLOSEST MATCH" CROSS REFERENCE

Hermetic Mil Spec Solutions		Sensata's Closest Hermetic Solutions		General Description		
Military Specification	M8805	PN	Military Specification	Configuration	Wire Leads	Threaded Mount
M8805/80-01	/80	10AT506-33-10		Plunger	2PDT	5/8-24
M8805/80-03	/80	10AT506-33-10		Plunger	2PDT	5/8-24
M8805/80-04	/80	10AT507-103-10		Plunger	4PDT	5/8-24
M8805/80-05	/80	10AT358-33-10		Plunger	2PDT	15/32-32
M8805/80-06	/80	10AT510-103-10		Plunger	4PDT	15/32-32
M8805/80-07	/80	10AT373-33-10	M8805/70-036	Roller	2PDT	15/32-32
M8805/80-08	/80	10AT374-103-10	M8805/70-040	Roller	4PDT	15/32-32
MS24594-1	/41	3AT152-32-10		Plunger	2PDT	3/4-20
MS27216-1	/8	10AT511-01		Leaf	SPDT	NA
MS27216-2	/8	10AT511-02-2		Leaf	SPDT	NA
MS27216-3	/8	10AT511-03-2		Leaf	SPDT	NA
MS27216-4	/8	10AT511-02-9		Leaf	SPDT	NA
MS27216-5	/8	10AT511-01		Leaf	SPDT	NA
MS27216-6	/8	10AT511-01		Leaf	SPDT	NA
M8805/82-002	/82	10AT509-01		Leaf	SPDT	NA
MS21321-1	/39	10AT506-33-10		Plunger	2PDT	5/8-24
MS21321-2	/39	10AT507-103-10		Plunger	4PDT	5/8-24
MS24331-1	/40	10AT506-33-10		Plunger	2PDT	5/8-24
MS27240-1	/43	10AT358-33-10		Plunger	2PDT	15/32 -32
MS27240-2	/43	10AT510-103-10		Plunger	4PDT	15/32 -32
MS27240-3	/43	10AT373-33-10	M8805/70-036	Roller	2PDT	15/32 -32
MS27240-4	/43	10AT374-103-10	M8805/70-040	Roller	4PDT	15/32 -32
MS27240-5	/43	10AT358-33-10		Plunger	2PDT	15/32 -32
MS27240-6	/43	10AT510-103-10		Plunger	4PDT	15/32 -32
MS27240-7	/43	10AT373-33-10	M8805/70-036	Roller	2PDT	15/32 -32
MS27240-8	/43	10AT374-103-10	M8805/70-040	Roller	4PDT	15/32 -32

<http://www.sensata.com/>

BUSINESS CENTER

Sensata Technologies Inc.
529 Pleasant Street
Attleboro, MA 02703, USA
Phone: +1 508-236-3800
Fax: +1 508-236-2349



Sensata
Technologies

The World Depends on Sensors and Controls

©2013 Sensata Technologies, Inc. All rights reserved worldwide. Printed in USA, revised April 2013.

Important Notice: Sensata Technologies reserves the right to make changes to, or to discontinue, any product or service identified in this publication without notice. Before placing orders, users should obtain the latest version of the relevant information to verify that the information being relied upon is current.

Sensata Technologies assumes no responsibility for customers' product designs or applications. Users must determine the suitability of the Sensata device described in this publication for their application, including the level of reliability required. Many factors beyond Sensata's control can affect the use and performance of a Sensata product in a particular application, including the conditions under which the product is used and the time and environmental conditions in which the product is expected to perform. As these factors are uniquely within the user's knowledge and control, it is essential that the user evaluate the Sensata product to determine whether it is fit for a particular purpose and suitable for the user's application.

Sensata Technologies products are sold subject to Sensata's Terms and Conditions of Sale which can be found at: www.sensata.com/terms.htm